

# CUSTOM

THE HIGH POWER STACK HORIZON  
2-3 PH From 150A to 2100A

- Voltage Supply 480-600-690V
- Current Rating from 150 to 2100A
- Designed to drive 1-2-3 Phase Loads
- Internal Fuse with Micro for Fuse Failure
- Stall Fan Protection for 1100 to 2100A
- Control Board with Plug in connections

CD AUTOMATION

POWERED BY INNOVATION



**The High Power Stack Horizon**



[www.cdautomation.com](http://www.cdautomation.com)

Custom Catalog 2018

Release n.1

# CUSTOM 2PH FROM 150 TO 800A



FROM 150A to 300A



FROM 450A to 800A

## GENERAL DESCRIPTION

- Custom 2PH has been specifically designed for OEM. This product can be customized
- All circuit board, fuses and Thyristor can be inspected just opening front door
- Input signal: SSR, Analog
- Zero Crossing, Burst Firing available at 4, 8 or 16 Cycles at 50% Power demand
- Electronic circuit fully isolated from power with constant current drain on input
- Heater Break alarm option to diagnose partial or total load failure and Thyristor Short circuit
- Internal fixed fuses are standard
- Current transformer integrated (with HB option)
- Special design for Heat sink with very high dissipation value
- Comply with EMC
- Panel Mounting
- IP20 Protection available as option

## TECHNICAL SPECIFICATION

VOLTAGE POWER SUPPLY	24V minimum to 600V and 690V on request		
VOLTAGE FREQUENCY	50 or 60 Hz no setting needed from 47 to 70 Hz		
NOMINAL CURRENT	150A - 210A - 300A - 450A - 550A - 800A		
INPUT SIGNAL	SSR	5:30Vdc	5mA Max (On $\geq$ 4Vdc Off $\leq$ 1Vdc)
	Voltage input	0:10Vdc	impedance 15 K Ohm
	Current input	0:20/4:20mA	impedance 100 Ohm
FIRING	Zero Crossing, Burst Firing with analog input signal only		
AUXILIARY VOLTAGE SUPPLY	90:130Vac 8VA Max		
	170:265Vac 8VA Max (Standard)		
	230:345Vac 8VA Max		
	300:530Vac 8VA Max (Standard)		
	510:690Vac 8VA Max		
HEATER BREAK ALARM	Microprocessor based with automatic setting via Digital Input, Relay Output 0,5A at 125V (option)		
MOUNTING	Panel mounting		
OPERATING TEMPERATURE	40 °C without derating. Over this temperature see below derating curve		
STORAGE TEMPERATURE	-25 °C to 70 °C Max		
ALTITUDE	Over 1000 m of altitude reduce the nominal current of 2% for each 100m		
HUMIDITY	From 5 to 95% without condense and ice		

## CURRENT DERATING AS FUNCTION OF CABINET TEMPERATURE

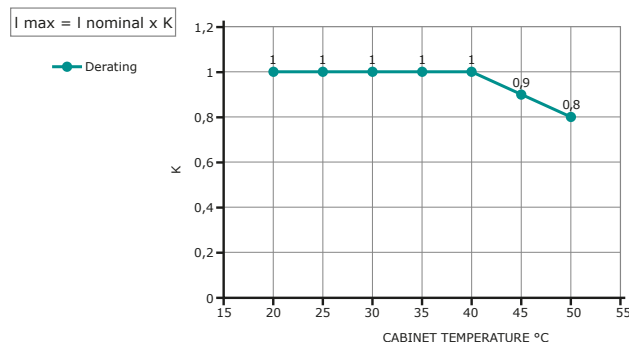

# WIRING CONNECTION CUSTOM 2PH from 150 to 800A

## CUSTOM 2 PH 150A to 800A

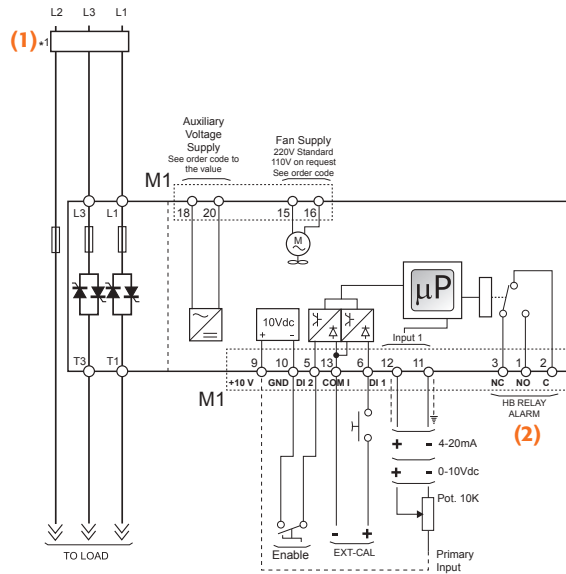

### NOTE:

#### LOAD TYPE

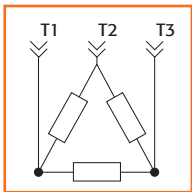

**DELTA**  
resistive or  
infrared lamps  
long and  
medium waves

#### LOAD TYPE

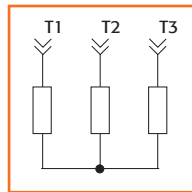

**STAR**  
without neutral  
resistive or  
infrared lamps  
long and  
medium waves

- (1) A suitable device must ensure that the unit can be electrically isolated from the supply, this allows the qualified people to work in safety. The user installation must be protected with electromagnetic circuit breaker or by fuse isolator. The semiconductor fuses are classified for UL as supplemental protection for semiconductor.
- (2) Only for the HB option, current transformer are mounted inside.

## DIMENSION AND FIXING HOLES

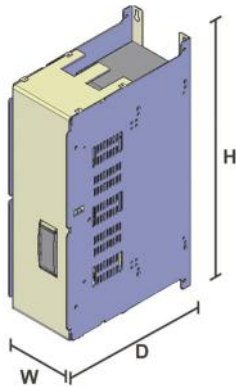

**CUSTOM 150-300A**

**S28** W 130mm - H 478mm - D 274mm - Kg 14

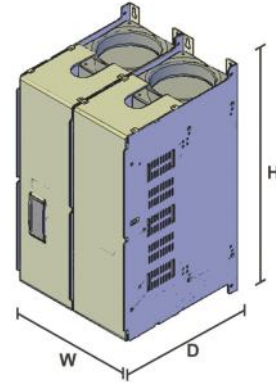

**CUSTOM 450-800A**

**S29** W 260mm - H 478mm - D 274mm - Kg 27

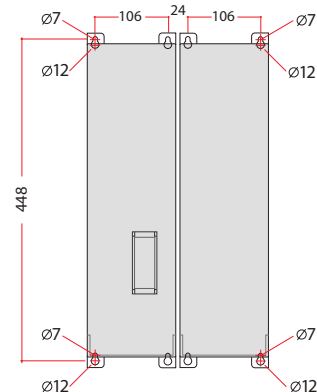
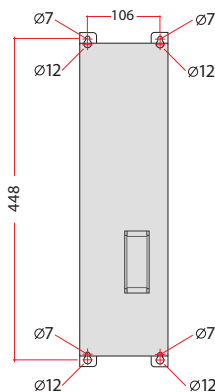

## OUTPUT FEATURES (POWER DEVICE)

CURRENT A	VOLTAGE RANGE V	RIPETITIVE PEAK REVERSE VOLTAGE (480V) (600V)		LATCHING CURRENT (mAeff)	MAX PEAK ONE CYCLE (10msec)	LEAKAGE CURRENT (mAeff)	I <sup>2</sup> T VALUE FOR FUSING tp=10msec	FREQUENCY RANGE Hz	SCR POWER LOSS I=Inom W FOR EACH PHASE	ISOLATION VOLTAGE Vac
150/210A	24+600V	1200	1600	300	4800	15	108000	47+70	671	2500
300A	24+600V	1200	1600	200	7800	15	300000	47+70	1165	2500
450A	24+600V	1200	1600	200	7800	15	300000	47+70	1484	2500
550A	24+600V	1200	1600	1000	17800	15	1027000	47+70	1555	2500
800A	24+600V	1200	1600	1000	17800	15	1027000	47+70	2281	2500

## FAN SPECIFICATION

CURRENT A		FAN VOLTAGE SUPPLY	POWER CONSUMPTION		MAX AIR FLOW FOR EACH FAN		FAN DIMENSION	NUMBER OF FAN FOR UNITS
from	to	V	watt for each fan		m3/min	m3/min	mm	
			50Hz	60Hz	50Hz	60Hz		
150	210	110 Opt.	19	16	2,6	3	120X120	1
150	210	230 Std.	17	15	2,6	3	120X120	1
300	800	110 Opt.	19	16	2,6	3	120X120	2 (1)
300	800	230 Std.	17	15	2,6	3	120X120	2 (1)

(1) at 800A the number of fans is 4

## CUSTOM 2PH 150-800

	1	2	3	4	5	6	7	8	9	10	11	12	13	14	15	16
<b>ORDERING CODE</b>	C	2	-	-	-	-	-	-	-	-	-	-	-	-	-	-

CURRENT	3	4	5	6	note
description	code				note
150A	0	1	5	0	
210A	0	2	1	0	
300A	0	3	0	0	
450A	0	4	5	0	
550A	0	5	5	0	
800A	0	8	0	0	

MAX VOLTAGE	7	note
description	code	note
600V	6	
690V	7	

VOLTAGE SUPPLY AUX	8	note
description	code	note
90:130V	1	1
170:265V	2	1
230:345V	3	1
300:530V	5	1
510:690V	6	1
600:760V	7	1

INPUT	9	note
description	code	note
SSR	S	
0:10V dc	V	
4:20 mA	A	

FIRING	10	note
description	code	note
Zero Crossing with SSR input	Z	
Burst Firing 4 Cycles on at 50% Power	4	2
Burst Firing 8 Cycles on at 50% Power	8	2
Burst Firing 16 Cycles on at 50% Power	6	2

CONTROL MODE	11	note
description	code	note
Open Loop	0	

OPTION	12	note
description	code	note
Measurement package including heater break alarm and current, voltage and power read out	H	
None	0	

FAN VOLTAGE	13	note
description	code	note
Fan 110V	1	
Fan 220V Standard	2	

APPROVALS	14	note
description	code	note
CE-ECM	0	

MANUAL	15	note
description	code	note
None	0	
Italian	1	
English	2	
German	3	
French	4	

LOAD CONNECTION	16	note
description	code	note
Standard in line with above code	1	
Thermal switch	2	
Fuse micro switch	3	
Fuse micro switch + thermal switch	4	

Note (1) Load voltage supply as value must be included in auxiliary voltage supply range.  
 Note (2) Burst firing is a zero crossing firing

# CUSTOM 3PH From 150 to 800A



## GENERAL DESCRIPTION

- Custom 3PH has been specifically designed for OEM. This product can be customized
- All circuit board, fuses and Thyristor can be inspected just opening front door
- Input signal: SSR, Analog
- Zero Crossing, Burst Firing available at 4, 8 or 16 Cycles at 50% Power demand
- Electronic circuit fully isolated from power with constant current drain on input
- Heater Break alarm option to diagnose partial or total load failure and Thyristor Short circuit
- Internal fixed fuses are standard
- Current transformer integrated (with HB option)
- Special design for Heat sink with very high dissipation value
- Comply with EMC
- Panel Mounting
- IP20 Protection available as option

## TECHNICAL SPECIFICATION

VOLTAGE POWER SUPPLY	24V minimum to 600V and 690V		
VOLTAGE FREQUENCY	50 or 60 Hz no setting needed from 47 to 70 Hz		
NOMINAL CURRENT	150A - 300A - 550A - 800A		
INPUT SIGNAL	SSR	5:30Vdc	5mA Max (On $\geq$ 4Vdc Off $\leq$ 1Vdc)
	Voltage input	0:10Vdc	impedance 15 K Ohm
	Current input	0:20/4:20mA	impedance 100 Ohm
FIRING	Zero Crossing, Burst Firing with analog input signal only		
AUXILIARY VOLTAGE SUPPLY	90:130Vac 8VA Max		
	170:265Vac 8VA Max (Standard)		
	230:345Vac 8VA Max		
	300:530Vac 8VA Max (Standard)		
	510:690Vac 8VA Max		
HEATER BREAK ALARM	Microprocessor based with automatic setting via Digital Input, Relay Output 0,5A at 125V (option)		
MOUNTING	Panel mounting		
OPERATING TEMPERATURE	40 °C without derating. Over this temperature see below derating curve		
STORAGE TEMPERATURE	-25 °C to 70 °C Max		
ALTITUDE	Over 1000 m of altitude reduce the nominal current of 2% for each 100m		
HUMIDITY	From 5 to 95% without condense and ice		

## CURRENT DERATING AS FUNCTION OF CABINET TEMPERATURE

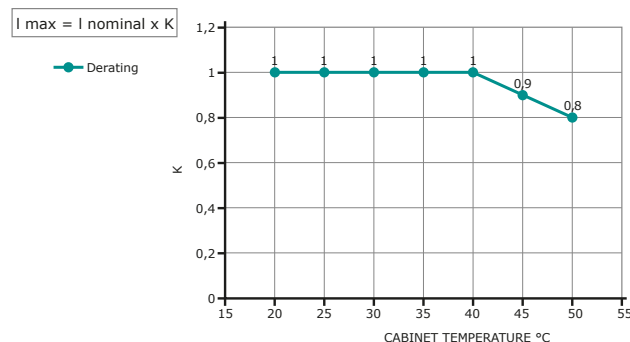

# WIRING CONNECTION CUSTOM 3PH FROM 150 TO 800A

## CUSTOM 3PH 150A to 800A

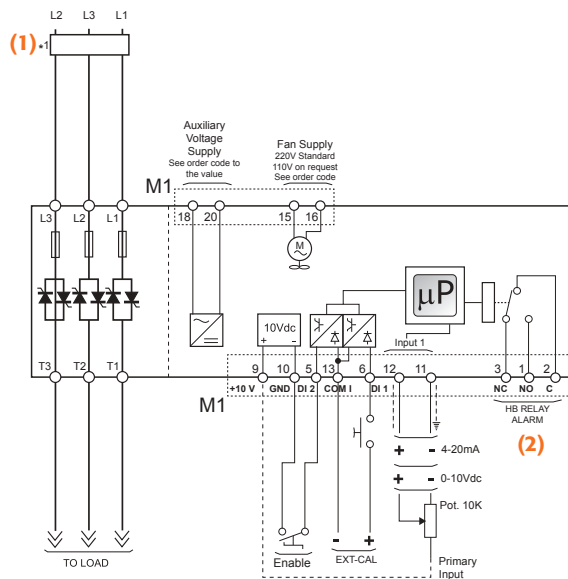

### NOTE:

#### LOAD TYPE

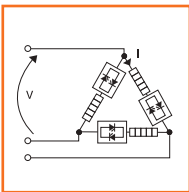

**OPEN DELTA**  
resistive or  
infrared lamps  
long and  
medium waves

#### LOAD TYPE

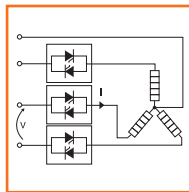

**STAR**  
without neutral  
resistive or  
infrared lamps  
long and  
medium waves

- (1) A suitable device must ensure that the unit can be electrically isolated from the supply, this allows the qualified people to work in safety. The user installation must be protected with electromagnetic circuit breaker or by fuse isolator. The semiconductor fuses are classified for UL as supplemental protection for semiconductor.
- (2) Only for the HB option, current transformer are mounted inside.

## DIMENSION AND FIXING HOLES

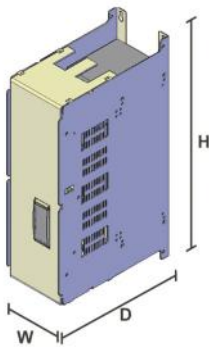

**CUSTOM 150A**

**S29** W 130mm - H 478mm - D 274mm - Kg14

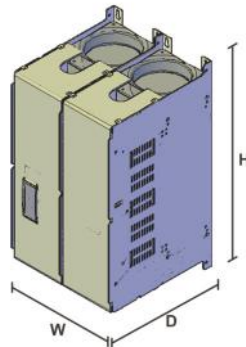

**CUSTOM 300A**

**S29** W 260mm - H 478mm - D 274mm - Kg27

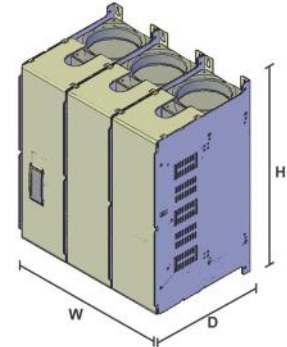

**CUSTOM 550-800A**

**S30** W 390mm - H 478mm - D 274mm - Kg42

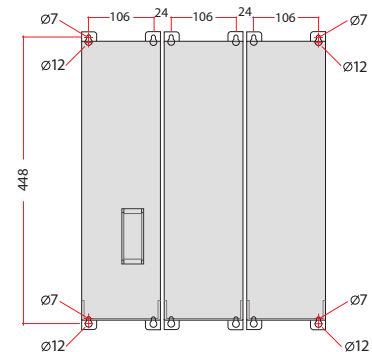
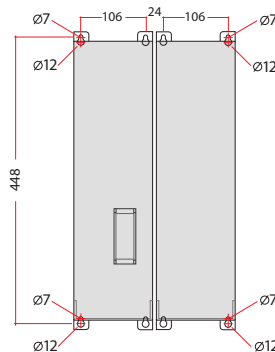
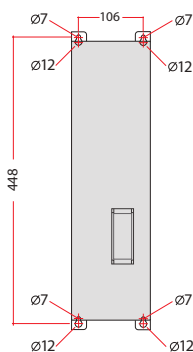

## OUTPUT FEATURES (POWER DEVICE)

CURRENT A	VOLTAGE RANGE V	RIPETITIVE PEAK REVERSE VOLTAGE (480V) (600V)		LATCHING CURRENT (mAeff)	MAX PEAK ONE CYCLE (10msec)	LEAKAGE CURRENT (mAeff)	I <sup>2</sup> T VALUE FOR FUSING tp=10msec	FREQUENCY RANGE Hz	SCR POWER LOSS I=Inom W FOR EACH PHASE	ISOLATION VOLTAGE Vac
150A	24+600V	1200	1600	300	4800	15	108000	47+70	805	2500
300A	24+600V	1200	1600	300	5250	15	128000	47+70	1439	2500
400A	24+600V	1400	1600	200	8000	15	306000	47+70	1640	2500
550A	24+600V	1400	1600	1000	17800	15	1027000	47+70	2333	2500
800A	24+600V	1400	1600	1000	17800	15	1027000	47+70	3400	2500

## FAN SPECIFICATION

CURRENT A		FAN VOLTAGE SUPPLY	POWER CONSUMPTION		MAX AIR FLOW FOR EACH FAN		FAN DIMENSION	NUMBER OF FAN FOR UNITS
from	to	V	watt for each fan		m3/min	m3/min	mm	
			50Hz	60Hz	50Hz	60Hz		
150	210	110 Opt.	14	16	2,6	3	120X120	2
150	210	230 Std.	16	15	2,6	3	120X120	2
300	800	110 Opt.	19	16	2,6	3	120X120	3 (1)
300	800	230 Std.	17	15	2,6	3	120X120	3 (1)

(1) at 800A the number of fans is 6

## CUSTOM 3PH 150-800

	1	2	3	4	5	6	7	8	9	10	11	12	13	14	15	16
ORDERING CODE	C	3	-	-	-	-	-	-	-	-	-	-	-	-	-	-

CURRENT	3	4	5	6
description	code			
150A	0	1	5	0
300A	0	3	0	0
550A	0	5	5	0
800A	0	8	0	0

MAX VOLTAGE	7
description	code
480V	4
600V	6
690V	7

VOLTAGE SUPPLY AUX	8
description	code
90:130V	1
170:265V	2
230:345V	3
300:530V	5
510:690V	6
600:760V	7

INPUT	9
description	code
SSR	S
0:10V dc	V
4:20 mA	A

FIRING	10
description	code
Zero Crossing with SSR input	Z
Burst Firing 4 Cycles on at 50% Power	4
Burst Firing 8 Cycles on at 50% Power	8
Burst Firing 16 Cycles on at 50% Power	6

CONTROL MODE	11
description	code
Open Loop	0

OPTION	12
description	code
Measurement package including heater break alarm and current, voltage and power read out	H
None	0

FAN VOLTAGE	13
description	code
Fan 110V	1
Fan 220V Standard	2

APPROVALS	14
description	code
CE-ECM	0

MANUAL	15
description	code
None	0
Italian	1
English	2
German	3
French	4

LOAD CONNECTION	16
description	code
Standard in line with above code	1
Standard + second thermal switch	2
Standard + fuse micro switch	3
Standard + fuse micro switch + fuse micro	4

Note (1) Load voltage supply as value must be included in auxiliary voltage supply range.  
 Note (2) Burst firing is a fast zero crossing firing



# HORIZON FOR SCR HIGH POWER STACK

## Custom 2-3 phase from 1100 to 2100A

### GENERAL DESCRIPTION

- Universal unit for input, firing mode, zero crossing and burst firing
- Integrated semiconductor fuses
- Fully configurable via frontal keypad
- Easy to use, with diagnostic and wiring diagram on front unit
- Removal of the complete phase by front unit without fork lift help
- Aluminum modular structure and copper treated against oxidation
- Suitable to drive normal resistance, medium and long waveform infrared
- Voltage supply 480-600-690V

### APPLICATION

- Petrochemicals
- Platform for oil extraction
- Conventional power generation
- Chemicals and pharmaceutical
- Autoclaves
- Furnaces
- Galvanic process

CUSTOM 2PH with IP20 option





## FEATURES

- Custom 2-3 PH is a full digital thyristor unit
- Suitable to drive resistive loads, two or three legs switching three wires load star or delta connected
- Frontal key pad standard to configure all the internal functions and parameters
- Measurement option to have following information:
  - RMS load current readout for each phase
  - Load voltage output
  - Total load power indication
  - HB alarm for total or partial load failure with relay output alarm
  - Selectable control mode for power, voltage and current
- Stall protection and alarm for faulty fan
- Universal input signal with automatic zero/span calibration
- Fuse failure microswitch for alarm indication
- Zero crossing and burst firing
- Second thermal switch for over temperature indication on each heat sink
- Comply with EMC rules, IP zero protection
- IP20 protection available as an option



## TECHNICAL SPECIFICATION

OPERATING TEMPERATURE	0+40°C over this temperature (see derating tab. at page 2)
MAX VOLTAGE POWER SUPPLY	480V, 600V or 690V
AUXILIARY VOLTAGE SUPPLY	90+265V, 20VA power consumption. Fan voltage supply: 230±15% standard
ANALOG INPUT	1 main reference, 4+20mA, 0+10V, 10KPOT
RELAY OUTPUT	Three configurable relay output and one critical alarm
FIRING	Zero crossing with SSR input and with analog input. Burst firing 4-8-16 cycle at 50% power demand
MEASUREMENT OPTION	This option allows these function: Current, Voltage and power readout and HB alarm for partial or total load failure
THERMAL PROTECTION	Thermal switch for heat sink over temperature with output contact free of voltage for external alarm. One additional thermal switch is used to inhibit electronic circuit board
FUSE FAILURE	Micro switch for each fuse for fuse failure indication

## CD AUTOMATION

## COMPETITORS

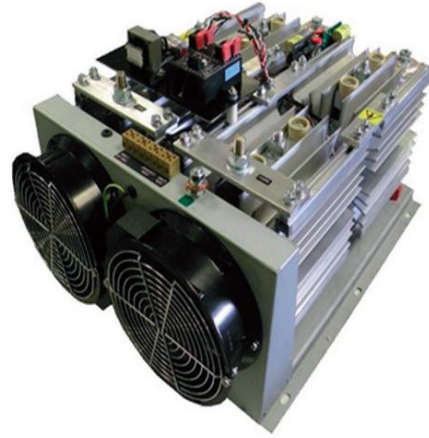

### OUR CUSTOM NEW PROJECT

### OLD FASHION PROJECT

Aluminum tunnel for ventilation

NO ventilation tunnel

Flux of air in direction of heat sink to increase the cooling efficiency

If you mount more than one unit in a cubicle you will have different air vortex intersection

You buy an units able to grow with your needs

You buy just heat sink plus thyristor

Fuses available inside the units

Fuses not available

Full visual Key Pad diagnostic

NO diagnostic

Heater break alarm to diagnostic partial or total load failure and short circuit on thyristor and current, voltage and power readout

NO heater break and read out

Fuse fault indication

NO fuse fault indication

### SPECIAL FEATURES - TOP DOWN MOUNTING

In the two phase unit, the phase module can be mounted in line one over the other and this allow to save space inside the cubicle.

In a cabinet 1m width and 2m high you can mount 3 off 2PH unit from 1100 to 2100A

In addition is easier to mount the copper bar for the power input and output and copper used is less because the copper bars are shorter.

The input bar and output can come from:

- BOTTOM PART
- UPPER PART
- SIDE PART

It's just your choice to decide from where!

If this mounting is used is available as an option an air deflector to avoid that hot air of the phase below invests the phase over mounted.



## MAINTAINABILITY IN FUNCTION

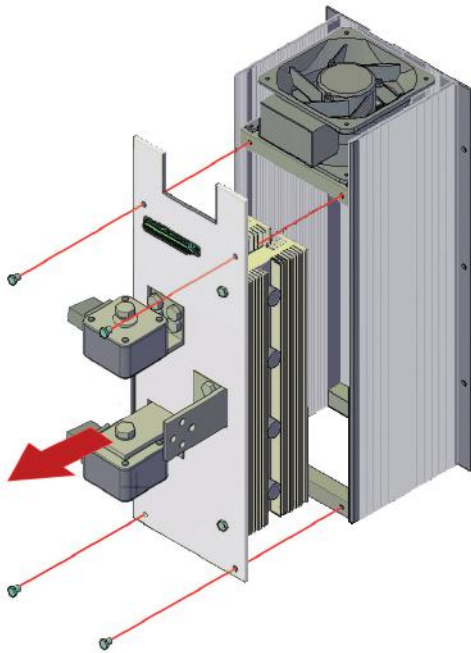

### THESE ARE OUR TARGETS:

- Each phase can be substituted by front unit by technician removing 4 screw without the help of fork lift
- The average weight of phase is 16 kg up to 2100 Amps
- Time required to substitute one phase not more than 20 minutes
- Plant downtime not more than 20 minutes, vital for important process
- When the operator substitute one phase all the auxiliary connection are plug in  
This allow to be fast and don't do mistakes in wiring
- Control board plug in for the connection

## MEASUREMENT OPTION

### HEATER BREAK ALARM

The heater break circuit diagnostic partial or total load failure.

It reads load resistance with an internal voltage and current transducer to calculate the resistance value  $V/I$ .

The heater break circuit is compensated for voltage fluctuation, in fact a voltage variation has no influence on resistance value because  $V/I$  ratio remain constant.

On this unit is possible to set the nominal resistance and the alarm sensitivity.

HB alarm in addition diagnostic short circuit on thyristors.

A normally open contact gives the alarm condition and an indication of the alarm type.

With measurement option is available the readout of current on each phase, load voltage and power on digital key pad on front unit.

## FIRING OPTION

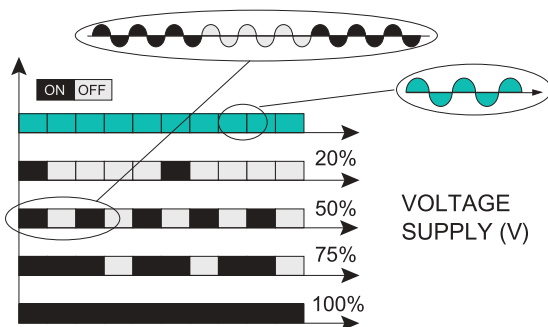

### BURST FIRING:

This firing is performed digitally within the thyristor unit at zero volts, producing no EMC interference.

Analogue is necessary for BF and the number of complete cycles can be 4-8-16 cycles on 50% power demand.

# CUSTOM HP2 from 1100 to 2100A

2 PH

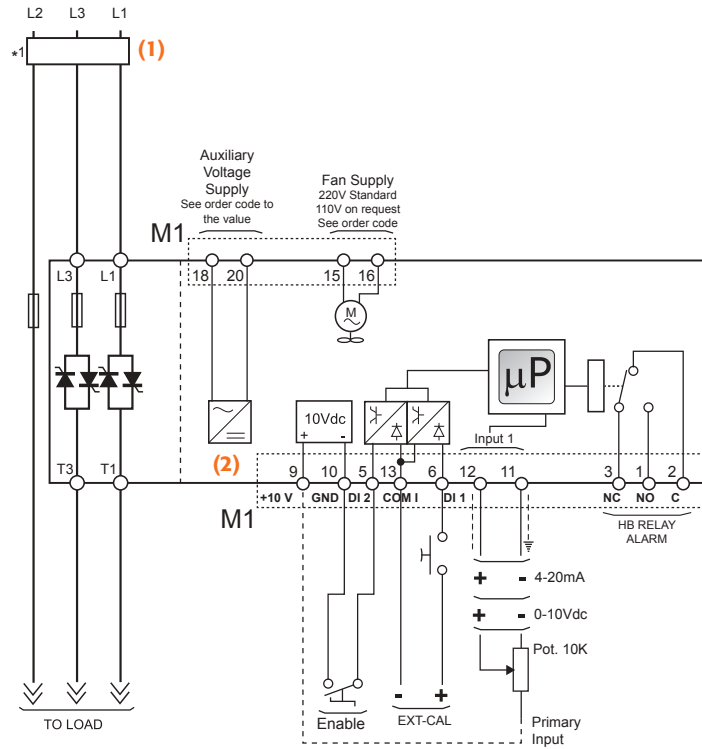

3 PH

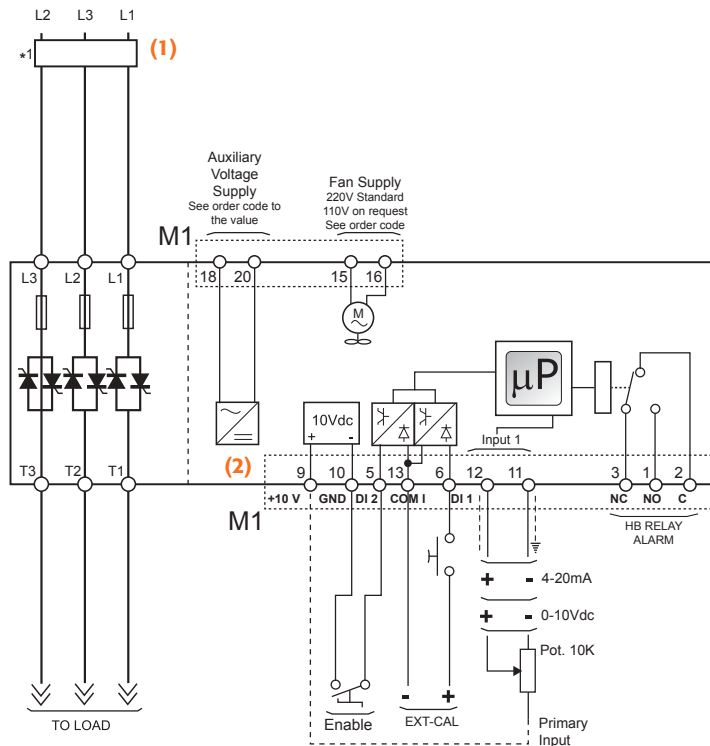

## NOTE:

LOAD TYPE

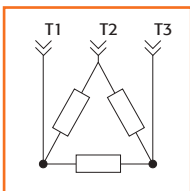

DELTA

LOAD TYPE

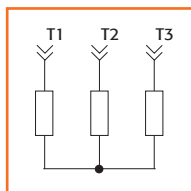

STAR

**Note (1)** The user must provide for protection external electromagnetic circuit breaker or fuse isolator

**Note (2)** The auxiliary voltage supply is wired externally as standard at 220V a.c.

## PHASE STACK THYRISTOR

CURRENT	MAX NOMINAL VOLTAGE	NOMINAL VOLTAGE
1100A	600V	690V
1400A	600V	690V
1600A	600V	690V
1800A	600V	690V
2100A	600V	690V

## ORDERING CODE

	1	2	3	4	5	6		7	8	9	10	11	12	13	14	15	16
<b>CUSTOM 2 Phase</b>	<b>C</b>	<b>2</b>	-	-	-	-	-	-	-	-	-	-	-	-	-	-	-
<b>CUSTOM 3 Phase</b>	<b>C</b>	<b>3</b>	-	-	-	-	-	-	-	-	-	-	-	-	-	-	-

CURRENT	3	4	5	6	
description	code				note
1100A	1	1	0	0	
1400A	1	4	0	0	
1600A	1	6	0	0	
1800A	1	8	0	0	
2100A	2	1	0	0	

MAX VOLTAGE	7	
description	code	note
480V	4	
600V	6	
690V	7	

VOLTAGE SUPPLY AUX	8	
description	code	note
No external power supply internal connection	0	
170:265V external voltage supply	2	

INPUT	9	
description	code	note
SSR	S	
0:10V dc	V	
4:20 mA	A	
Potentiometer with internal power supply	K	

FIRING	10	
description	code	note
Zero Crossing with SSR input	Z	
Burst Firing settable from 1 to 255 cycles at 50% power demand	B	1

- Note (1)** We suggest to set over 16 cycles.  
**Note (2)** Available just on 2 PH.  
**Note (3)** See measurement option features page 9

CONTROL MODE	11	
description	code	note
Open Loop	0	
Voltage feed back	U	
Power feed back	W	
Current feed back	I	

OPTION	12	
description	code	note
Measurement package including heater break alarm and current, voltage and power read out	H	3

FAN VOLTAGE	13	
description	code	note
Fan 220V	2	

APPROVALS	14	
description	code	note
CE-EMC + IP0 protection standard	0	
CE-EMC + IP20 protection (option)	1	

MANUAL	15	
description	code	note
None	0	
Italian	1	
English	2	
German	3	
French	4	

LOAD CONNECTION	16	
description	code	note
Std with phase mounted side by side 2-3 PH version	1	
Phase one on the top of phase two with air deflector	2	2

## CURRENT RATING

	Cabinet Temperature		
	40°C	45°C	50°C
1100A	1036A	978A	
1400A	1299A	1227A	
1600A	1600A	1514A	
1800A	1810A	1711A	
2100A	1964A	1857A	

All the above current rating are referred at different cabinet temperature with the same junction temperature of thyristors

## DIMENSIONS



**2 PHASE UNIT 1100A**

**S32** H 550 x W 523 x D 320 - 49kg.



**3 PHASE UNIT 1100A**

**S33** H 550 x W 717 x D 320 - 72kg.



**2 PHASE UNIT  
1400A - 1600A - 1800A**

**S35** H 730 x W 523 x D 320 - 59/75kg.



**3 PHASE UNIT  
1700A - 1900A - 2100A - 2700A**

**S36** H 730 x W 717 x D 320 - 86/110kg.







### **Italy**

CD Automation Srl  
Via Picasso, 34/36  
20025 Legnano MI  
Italy  
**T** +39 0331 577479  
**F** +39 0331 579479  
sales@cdautomation.com  
www.cdautomation.com

### **India**

M/s Toshcon CD Automation Pvt. Ltd.  
H1 - 75 Gegal Industrial Area  
Ajmer - 305023 (Raj.)  
India  
**T** +91 145 2791112  
**T** +91 145 6450601/2/3  
sales.cd@toshcon.com  
www.cdautomation.in

### **England**

CD Automation UK Ltd  
Unit 9 Harvington Business Park  
Brampton Road, Eastbourne  
East Sussex, BN22 9BN  
England  
**T** +44 1323 811100  
info@cdautomation.co.uk  
www.cdautomation.co.uk