

# MLC 9000+ LOOP CONTROLLER MODULE INSTALLATION MANUAL 59326-2



**CAUTION:** Installation and configuration should be performed only by personnel who are technically competent to do so. Local Regulations regarding electrical installation & safety must be observed.

## 1. INSTALLATION - MECHANICAL

### 1.1 GENERAL DESCRIPTION

The MLC 9000+ System - comprising one or more Bus Modules each with up to eight Loop Modules - is designed for installation in an enclosure which is sealed against the ingress of dust and moisture. The enclosure must contain sufficient length of 35mm Top-Hat DIN mounting rail to accommodate the system modules (see below) plus an extra 50mm of rail to permit modules to be separated for removal/replacement. The space required by the MLC 9000+ modules is shown below.

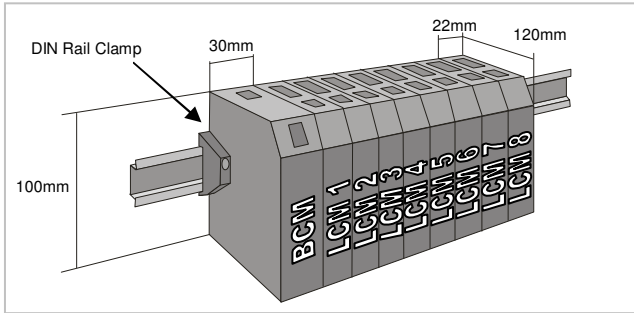

**NOTE:** An additional 60mm of space is required above and below the system modules to permit ventilation and to accommodate wiring bend radii to enclosure trunking or conduits. Allow sufficient slack in all cables inside the trunking to permit "hot" swapping of modules (i.e. modules to be removed/replaced whilst the system is under power).



**WARNING:** The maximum of eight Loop Module's per Bus Module must not be exceeded.

It is recommended that (a) some means of preventing unauthorised access to the enclosure interior (e.g. lockable doors) is provided, and (b) that a suitable DIN rail clamp be used, once the MLC 9000+ system is fully installed, to prevent the system from moving on the DIN rail.

### 1.2 VENTILATION

Under normal circumstances, no forced ventilation is required and the enclosure need not contain ventilation slots, but temperatures within the enclosure must be within specification.

### 1.3 INSTALLING A LOOP MODULE

The MLC 9000+ system is installed in the following order:

1. Bus Communications Module (refer to Bus Module installation instructions)
2. Interconnect Module(s)
3. First Loop Controller Module
4. Second Loop Controller Module
5. Third Loop Controller Module etc.....

To install the Loop Module follow the instructions below:



**CAUTION: HOT SWAPPING OF LOOP CONTROLLER MODULES.**

Although hot swapping of Loop Modules is possible, caution must be exercised in order to eliminate the risk of receiving an electric shock due to the possibility of up to 240VAC being present at the relay terminals of an Loop Module. Before removing any connectors from a Loop Module, please ensure that all hazardous voltages have been isolated from the appropriate connectors.

### 1.3.1 Installing an Interconnect Module

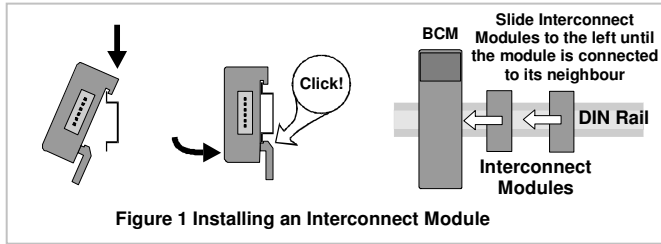

Figure 1 Installing an Interconnect Module

### 1.3.2 Installing a Loop Module

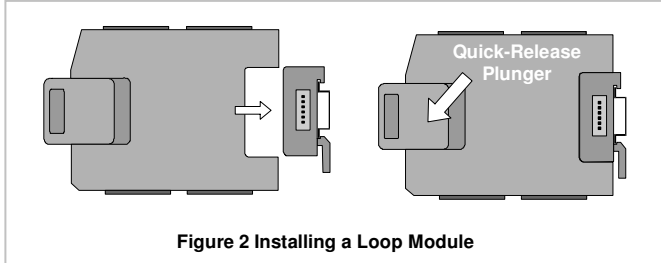

Figure 2 Installing a Loop Module

### 1.4 REMOVING A LOOP MODULE

#### 1.4.1 Removing a Loop Module

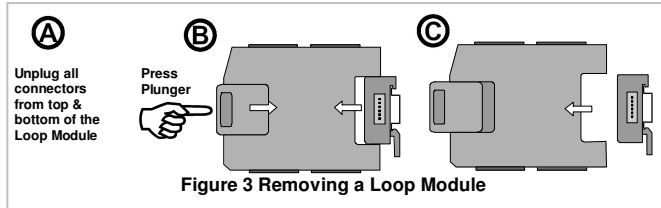

Figure 3 Removing a Loop Module

#### 1.4.1 Removing an Interconnect Module

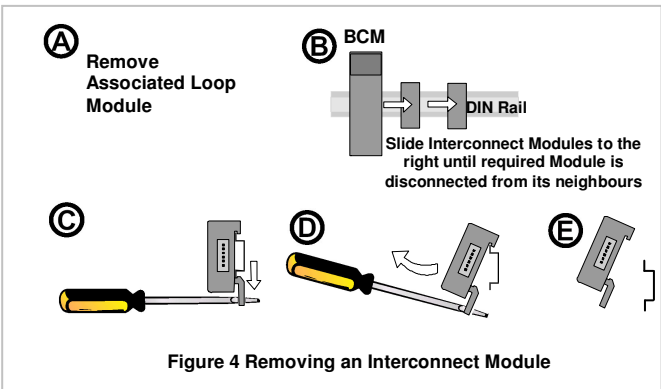

Figure 4 Removing an Interconnect Module

## 2. INSTALLATION - ELECTRICAL

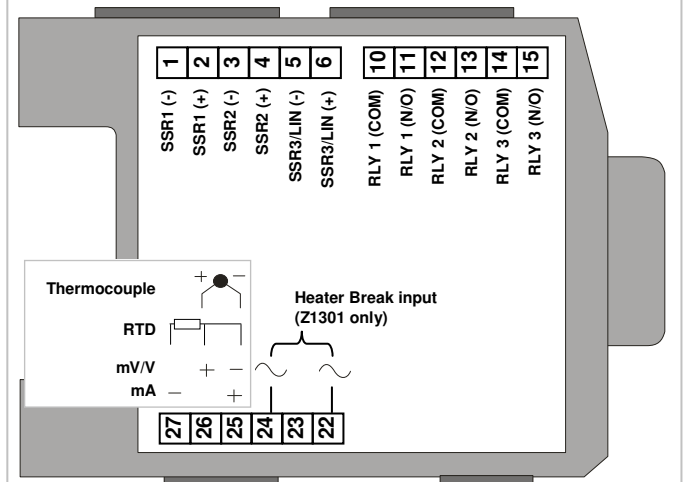
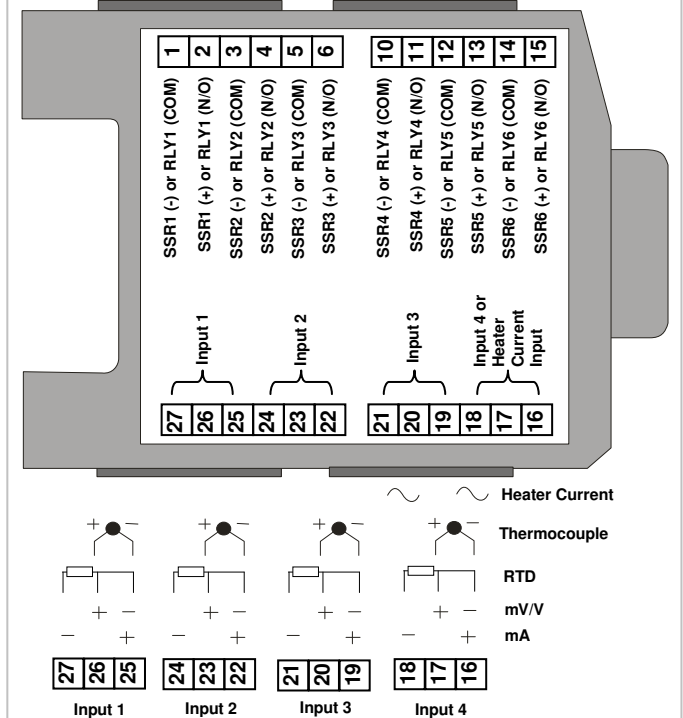

Figure 5 - Single Loop Electrical Connections

Module Type	Outputs					
	1	2	3	4	5	6
Z3611	Relay	Relay	Relay	Relay	Relay	Relay
Z3621	SSR	SSR	SSR	SSR	SSR	SSR
Z3651	SSR	SSR	SSR	Relay	Relay	Relay
Z4610	Relay	Relay	Relay	Relay	Relay	Relay
Z4620	SSR	SSR	SSR	SSR	SSR	SSR
Z4660	SSR	SSR	SSR	SSR	Relay	Relay



Note: Heater current input is only applicable to module variants Z3611, Z3621 and Z3651

Figure 6 - Multiple Loop Electrical Connections

## 2.1 Installation Considerations

Ignition transformers, arc welders, mechanical contact relays and solenoids are all common sources of electrical noise in an industrial environment and therefore the following guidelines MUST be followed.

1. If the instrument is being installed in existing equipment, the wiring in the area should be checked to ensure that good wiring practices have been followed.
2. Noise-generating devices such as those listed should be mounted in a separate enclosure. If this is not possible, separate them from the instrument, by the largest distance possible.
3. If possible, eliminate mechanical contact relays and replace with solid-state relays. If a mechanical relay being powered by an output of this instrument cannot be replaced, a solid-state relay can be used to isolate the instrument.
4. Do not run signaling cables adjacent to power-carrying conductors. If the wiring is run in a conduit, use a separate conduit for the signal wiring. Use of shielded cable is recommended and this must be grounded at one point only.

## 2.2 Noise Suppression at Source

Usually when good wiring practices are followed, no further noise protection is necessary. Sometimes in severe electrical environments, the amount of noise is so great that it has to be suppressed at source. Many manufacturers of relays, contactors etc supply 'surge suppressors' which mount on the noise source. For those devices that do not have surge suppressors supplied, Resistance-Capacitance (RC) networks and/or Metal Oxide Varistors (MOV) may be added.

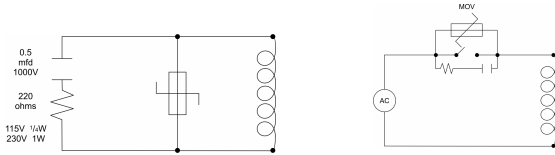

Inductive coils - MOVs are recommended for transient suppression in inductive coils, connected in parallel and as close as possible to the coil. Additional protection may be provided by adding an RC network across the MOV. Contacts - Arcing may occur across contacts when they contact open and close. This results in electrical noise as well as damage to the contacts. Connecting a properly sized RC network can eliminate this arc. For circuits up to 3 amps, a combination of a 47 ohm resistor and 0.1 microfarad capacitor (1000 volts) is recommended. For circuits from 3 to 5 amps, connect two of these in parallel.

## 2.3 Thermocouple Inputs

The correct type of extension leadwire/compensation cable must be used for the entire distance between the Loop Module connector and the thermocouple; correct polarity must be observed throughout and joints in the cable should be avoided. If the thermocouple is grounded, this must be done at one point only. If the thermocouple extension leadwire is shielded, this shield must also be grounded at one point only.

## 2.4 RTD Inputs

The extension leads should be of copper and the resistance of the wires connecting the resistance element should not exceed 50Ω per lead (the leads should be of equal resistance). For three wire RTDs, connect the resistive leg and the common legs of the RTD as illustrated. For a two wire RTD a wire link should be used in place of the third wire. Two wire RTDs should only be used when the leads are less than 3 metres long. Avoid cable joints.

## 2.5 Heater Current Input

For single loop modules with a heater current input the main heater conductor should be passed through a current transformer (CT) the secondary should then be connected to the input terminals of the Loop Module. A value of CT should be selected so that the secondary has a maximum current value of 50mA.

For multiple loop modules with a heater current input a single CT is used. Each of the main heater conductors is passed through the single CT. The value of CT needs to be calculated to be able to withstand the maximum current in all three conductors at the same time. If a CT can not be found that is of sufficient size then one of the conductors can be passed through the CT in the opposite direction to the other two this has the effect of cancelling out one of the other conductors and as such reducing the secondary current.

Current Transformers available from your local supplier:

25:0.05	part number 85258
50:0.05	part number 85259
100:0.05	part number 85260

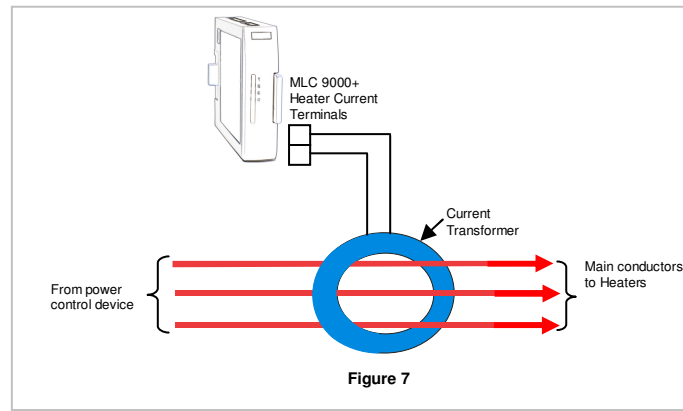

Figure 7

## 3. LOOP MODULE SPECIFICATIONS

GENERAL			
<b>Function</b>	Each Loop Module performs the control functions and provides the input and output connections for its own control loops. Up to 4 universal process inputs and up to 6 outputs. (dependent on model variant)		
<b>Types Available</b>	Z1200: One Universal input, two SSR/relay outputs (selectable) Z1300: One Universal input, two SSR/relay outputs and one Linear output or three SSR/relay outputs (selectable) Z1301: One Universal input, one Heater Break input, two SSR/relay outputs and one Linear or three SSR/relay outputs (selectable) Z3611: Three Universal inputs, one Heater Break input, six relay outputs Z3621: Three Universal inputs, one Heater Break input, six SSR outputs Z3651: Three Universal inputs, one Heater Break input, three SSR outputs and three Relay outputs Z4610: Four Universal inputs, six relay outputs Z4620: Four Universal inputs, six SSR outputs Z4660: Four Universal inputs, four SSR outputs and two Relay outputs		
<b>Process input</b>	Type and scale user selectable (see Process inputs table) Sample rate = 10 per second (100ms)		
<b>Heater Current Input</b>	Measures a Heater current value via an external CT for use by the Heater Break Alarm function.		
PROCESS INPUTS			
Types available (Range Minimum – Range Maximum)			
Thermocouple	RTD	DC Linear	
B (100 – 1824°C) B (212 – 3315°F)	N (0.0 – 1399.6°C) N (32.0 – 2551.3°F)	PT100 (-199.9 – 800.3°C) PT100 (-327.3 – 1472.5°F)	0 – 20mA 4 – 20mA
J (-200.1 – 1200.3°C) J (-328.2 – 2192.5°F)	R (0 – 1759°C) R (32 – 3198°F)	NI 120 (-80.0 – 240.0°C) NI 120 (-112.0 – 464.0°F)	0 – 50mA 10 – 50mV
K (-240.1 – 1372.9°C) K (-400.2 – 2503.2°F)	S (0 – 1759°C) S (32 – 3198°F)		0 – 5V 1 – 5V
L (-0.1 – 761.4°C) L (31.8 – 1402.5°F)	T (-240.0 – 400.5°C) T (-400.0 – 752.9°F)		0 – 10V 2 – 10V
E (-250 – 999°C) E (-418 – 1830°F)			
THERMOCOUPLE INPUTS			
<b>Measurement Accuracy</b>	Better than ±0.1% of range span ±1 LSD. Note: Reduced performance with Type "B" thermocouple between 100 – 600°C (212 – 1112°F). Type "T" accuracy is ±0.5% below -100°C		
<b>Linearisation Accuracy</b>	Better than ±0.2°C any point, for 0.1°C resolution ranges (0.05°C typical) Better than ±0.5°C any point, for 1°C resolution ranges.		
<b>CJC</b>	Better than ±1°C over operating temperature range.		
<b>Sensor Resistance Influence</b>	<10Ω: as measured accuracy 100Ω: <0.1% of range span error 1000Ω: <0.5% of range span error		
<b>Thermocouple Calibration</b>	Complies with BS4937, NBS125 & IEC584		

RTD INPUTS	
<b>Measurement Accuracy</b>	±0.1% of range span ±1 LSD for single Loop Modules ±0.2% of range span ±1 LSD for multiple Loop Modules
<b>Linearisation Accuracy</b>	Better than ±0.2°C any point (0.05°C typical)
<b>Temperature Stability</b>	0.01% of range span/°C change in ambient temperature.
<b>Lead Compensation</b>	Automatic to 50Ω maximum lead resistance, giving less than 0.5% of span additional error.
<b>RTD Sensor Current</b>	150µA ±10µA
<b>PT100 Calibration</b>	Complies with BS1904 & DIN43760 (0.00385Ω/°C)
DC LINEAR INPUTS	
<b>Measurement Accuracy</b>	Better than ±0.1% of programmed range span ±1 LSD.
<b>Temperature Stability</b>	0.01% of range span/°C change in ambient temperature
<b>Input Resistance</b>	mV Input: >1MΩ V Input: 47kΩ mA Input: 4.7Ω
<b>Maximum Resolution</b>	-32000 to 32000. Equivalent to a 16-bit ADC
HEATER CURRENT INPUT (Z1301, Z3611, Z3621 and Z3651 only)	
<b>Input Sampling Method</b>	Delta-sigma at 1kHz
<b>Input Resolution</b>	8 bits over 250mseconds rolling window
<b>Accuracy</b>	Better than ±2% of span
<b>Isolation</b>	Via external current transformer
<b>Internal Burden</b>	15Ω
<b>Input Span</b>	0 – 60mA rms. (assuming sinusoidal input current waveform)
<b>Range Maximum</b>	Adjustable 0.1A to 1000.0A
<b>Range Minimum</b>	Fixed at 0A
RELAY OUTPUTS	
<b>Contact Type</b>	Single pole single throw (SPST) Normally open contacts (N/O)
<b>Rating</b>	2A resistive @ 120/240VAC
<b>Lifetime</b>	>500,000 operations at rated voltage/current
SSR DRIVE OUTPUTS	
<b>Drive Capability</b>	12V DC nominal (10V DC minimum) at up to 20mA load
<b>Isolation</b>	Isolated from process input and relay outputs. Not isolated from each other or linear outputs. Not isolated from other similar outputs in the same system.
LINEAR OUTPUT	
<b>Resolution</b>	Eight bits in 250ms (10 bits in 1 second typical)
<b>Accuracy</b>	±0.25% (mA into 250Ω load, V into 2kΩ load) Degrading linearly to ±0.5% for increasing burden to maximum drive capability.
<b>Update Rate</b>	10 samples per second
<b>Drive Capability</b>	0-20mA: 500Ω maximum load 4-20mA: 500Ω maximum load 0-5V: 500Ω minimum load 0-10V: 500Ω minimum load
<b>Isolation</b>	Isolated from process input and relay outputs. Not isolated from SSR Drive outputs or other similar outputs in the same system
OPERATING CONDITIONS	
<b>Ambient Temperature</b>	0°C to 55°C (operating); -20°C to 80°C (storage)
<b>Relative Humidity</b>	30% - 90% non-condensing (operating and storage)
<b>Supply Voltage</b>	Powered by Bus Module within its operating conditions
APPROVALS	
<b>EMC Standard</b>	EN61326-1.
<b>Safety</b>	Complies with EN61010-1 and UL 3121-1.
PHYSICAL	
<b>Dimensions</b>	Height: - 100mm; Width: - 22mm; Depth: - 120mm
<b>Mounting</b>	35mm x 7.5mm Top Hat DIN rail mounting via Interconnect Module (EN50022, DIN46277-3)
<b>Connector Types</b>	All 5.08mm Combricon type
<b>Weight</b>	0.15kg