

## $\frac{1}{4}$ -DIN, $\frac{1}{8}$ -DIN & $\frac{1}{16}$ -DIN TEMPERATURE CONTROLLERS INPUT CALIBRATION PROCEDURE

September 1996

**NOTE:** Calibration should be attempted only on Controllers on which calibration errors have been encountered (see **CALIBRATION CHECK**) and should only be performed by personnel who are technically competent and authorised to do so.

### CALIBRATING THE UNIVERSAL INPUT

#### Equipment Required

1. Input source with an accuracy better than  $\pm 0.05\%$  of reading:
  - (a) Thermocouple inputs - complete with  $0^{\circ}\text{C}$  reference facility, appropriate thermocouple functions and compensating leads (or equivalent).
  - (b) DC linear inputs - 0 - 5V and 0 - 20mA.
  - (c) RTD inputs - decade resistance box with connections for three-wire input (or equivalent)
2. Appropriate case assembly ( $\frac{1}{4}$ -DIN,  $\frac{1}{8}$ -DIN or  $\frac{1}{16}$ -DIN) wired for appropriate input supply (90 - 264V AC 50/60Hz, 20 - 50V AC 50/60Hz or 22 - 65V DC).

#### Calibration Procedure

1. Ensure that the Controller is powered-off and that the mains (line) lead is disconnected. On the CPU PCB, fit the appropriate link jumpers (see Table 1 and Figure 1, Figure 2 or Figure 3 as appropriate to the type of Controller). Connect the appropriate input lead (see Figure 4 or Figure 5).
2. Connect the mains (line) lead to the Controller. Power-up the Controller and leave switched on for five minutes (for RTD and DC Linear inputs) or 30 minutes (for thermocouple inputs), then power-down.
3. Put the Controller in Calibration Mode by powering-up the Controller and, within 30 seconds of power-up, holding down the Lower and Function keys simultaneously for approximately five seconds. The upper display will then show Input Type Number, in the form:



The upper display shows the text "1P\_1" in a digital font.

and the lower display will show:



The lower display shows the text "CAL" in a digital font.

Using the Raise/Lower keys, change the input type number as required (see Table 1).

**NOTE:** If required, only one input type may be calibrated. **Exception:** If it is required to calibrate the thermocouple input (Input Type 5), it is necessary first to calibrate the DC 0 - 50mV input (Input Type 1).

4. Press the Auto/Manual key to change the upper display to show:



The upper display shows four horizontal dashes " \_ \_ \_ \_ " in a digital font.

After a few seconds, the upper display will either (a) return to the initial Input Type Number display if calibration was successful, or (b) display:



The upper display shows the text "FAIL" in a digital font.

In the latter case, the link jumpers and wiring should be checked.

Table 1 Universal Input Type Selection

Input Type No.	Input Type	Calibration Input	Link Jumper Settings		
			LJ1	LJ2	LJ3
1	DC - 0 - 50mV	50mV DC	Parked	Parked	Parked
2	DC 0 - 10V	10V DC	Fitted	Parked	Parked
3	DC 0 - 20mA	20mA DC	Parked	Fitted	Parked
4	RTD Three-wire	200Ω	Parked	Parked	Parked
5	Thermocouple	0°C "K"	Parked	Parked	Fitted

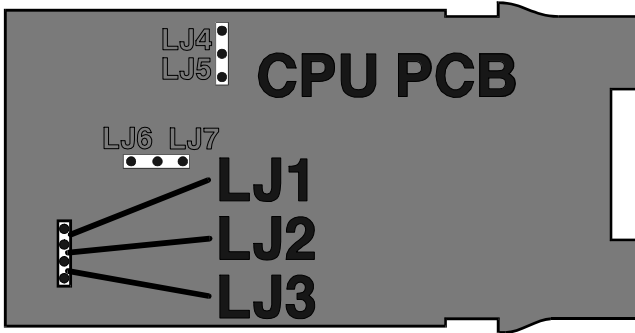

Figure 1 1/16-DIN Link Jumpers (Relay/SSR Output 1)

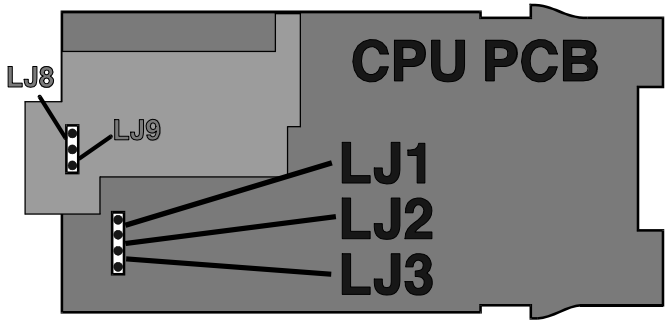

Figure 2 1/16-DIN Link Jumpers (DC Output 1)

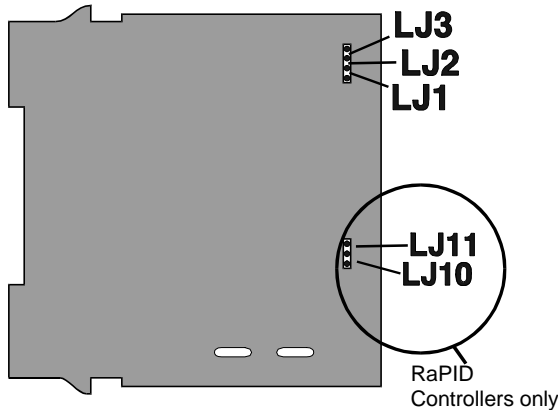

Figure 3 1/4-DIN/1/8-DIN Series Link Jumpers

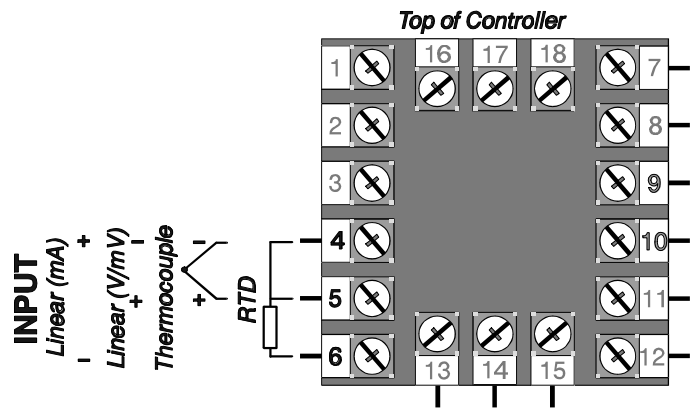

Figure 4 1/16-DIN Universal Input Connections

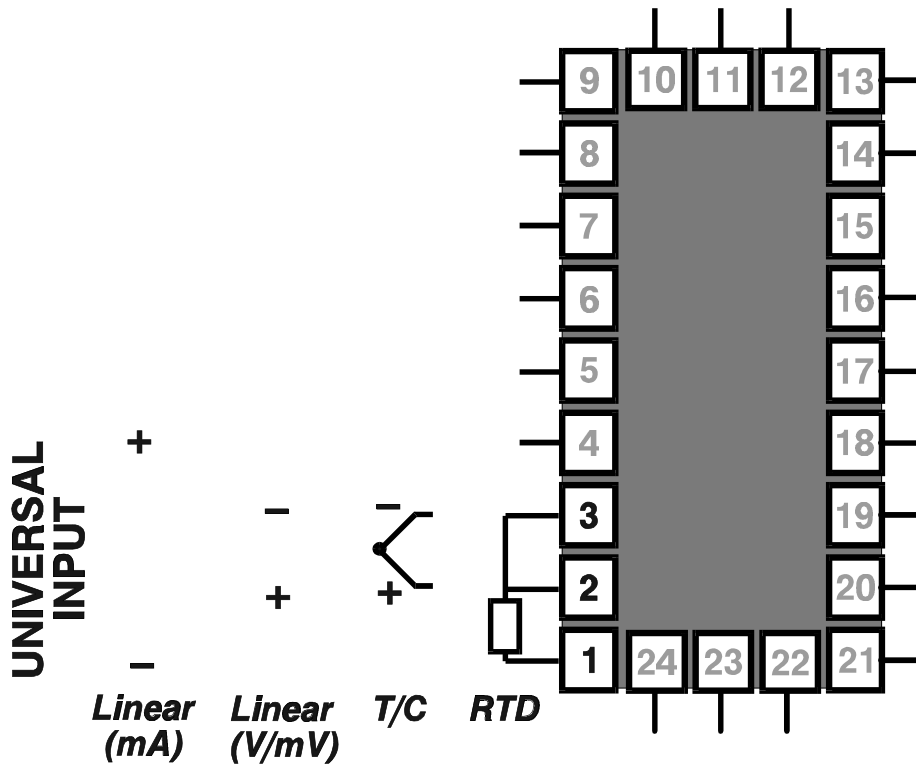

Figure 5 1/4-DIN/1/8-DIN Universal Input Connections

5. To calibrate all inputs, repeat Steps 1 to 4 for each of the other input types (see Table 1) until all five input types have been successfully calibrated.

**NOTE:** Input Type 5 should be calibrated using the appropriate Type K compensating lead (between Terminals 2 & 3 on  $\frac{1}{4}$ -DIN/ $\frac{1}{8}$ -DIN Controllers, Terminals 4 & 5 on  $\frac{1}{16}$ -DIN Controllers,). The Controller should be powered-up and remain powered up for at least 30 minutes with this lead connected before the input is calibrated.

The universal input calibration procedure is now complete.

## CALIBRATING THE SECONDARY ANALOGUE INPUT (RaPID CONTROLLERS ONLY)

### Equipment Required

1. DC linear input source (0 - 5V and 0 - 20mA) with an accuracy better than  $\pm 0.05\%$  of reading.
2. Appropriate case assembly ( $\frac{1}{4}$ -DIN or  $\frac{1}{8}$ -DIN) wired for appropriate input supply (90 - 264V AC 50/60Hz, 20 - 50V AC 50/60Hz or 22 - 65V DC).

### Calibration Procedure

1. Ensure that the Controller is powered-off and that the mains (line) lead is disconnected. On the CPU PCB, configure link jumpers LJ10 and LJ11 (see Table 2 and Figure 3). Connect the remote set-point input lead (see Figure 6).
2. Connect the mains (line) lead to the Controller. Power-up the Controller and leave switched on for five minutes, then power-down.
3. Put the Controller in Calibration Mode by powering-up the Controller and, within 30 seconds of power-up, holding down the Lower and Function keys simultaneously for approximately five seconds. The upper display will then show Input Type Number, in the form:



and the lower display will show:



Using the Raise/Lower keys, change the input type number as required (see Table 2).

**NOTE:** If required, only one input type may be calibrated.

4. Press the Auto/Manual key to change the upper display to show:



After a few seconds, the upper display will either (a) return to the initial Input Type Number display if calibration was successful, or (b) display:



In the latter case, the link jumpers and wiring should be checked.

5. To calibrate all inputs, repeat Steps 1 to 4 for each of the other input types (see Table 2) until all three secondary analogue input types have been successfully calibrated.

Table 2 Secondary Analogue Input Type Selection

Input Type No.	Input Type	Calibration Input	Link Jumper Settings	
			LJ10	LJ11
7	Remote Setpoint, Linear DC mV	50mV DC	Parked	Parked
8	Remote Setpoint, Linear DC V	10V DC	Parked	Fitted
9	Remote Setpoint, Linear DC mA	20mA DC	Fitted	Parked

**NOTE:** No calibration is required if the secondary analogue input is to be used as a Remote Setpoint Potentiometer input or for Dual Setpoint switching.

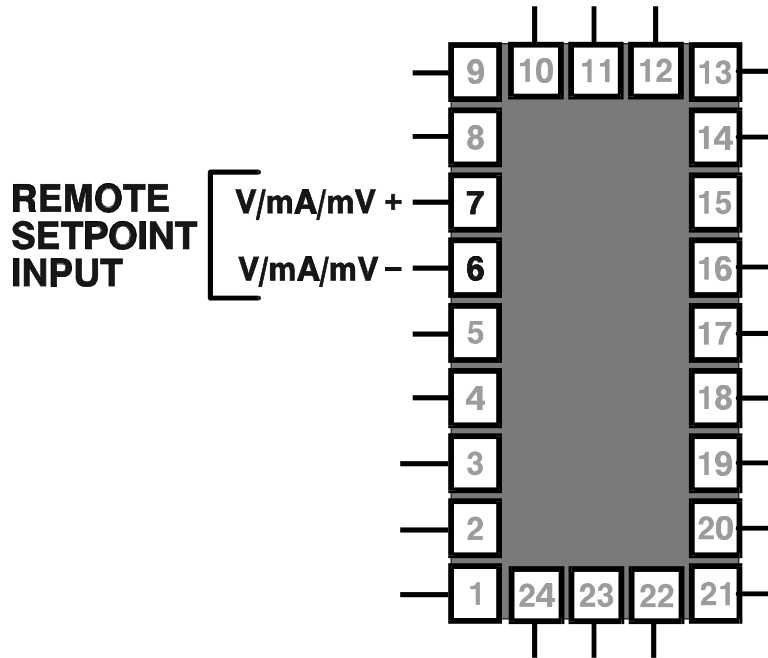

Figure 6  $\frac{1}{4}$ -DIN/ $\frac{1}{8}$ -DIN Controllers - Secondary Analogue Input

### EXIT FROM CALIBRATION MODE

To exit from Calibration Mode, press the Lower and Function keys simultaneously.

**NOTE:** An automatic exit is made from Calibration Mode if there is no key activity for two minutes.

### CALIBRATION CHECK

1. Set the Controller to the required configuration (using link jumpers and front panel entry) as described in the appropriate Product Manual.
3. Power-up the Controller and leave it powered-up for at least five minutes (for RTD and DC linear inputs) or at least 30 minutes (for thermocouple inputs).
2. After the appropriate delay for stabilisation has elapsed, check the calibration by connecting the appropriate input source and checking a number of cardinal points.