

USER'S MANUAL

Rev. 01/2025

REVO *RTL* *RTL03RS-1* *RTL06RS-1*

002

M-RTL0306RS-1



CD Automation S.r.l.

Via Picasso, 34/36 - 20025 Legnano (MI) - Italy

Tel. +39 0331 577479 - Fax +39 0331 579479

E-mail: info@cdautomation.com - Web: www.cdautomation.com



Declaration of conformity

Declaration of conformity - Dichiarazione di Conformità

PRODUCT MANUFACTURER / PRODUTTORE:



CD Automation S.R.L.
Controllers, Drives & Automation

Via Picasso, 34/36 - 20025 Legnano (MI)- Italy
P.I. 08925720156 -Tel. +39 0331 577479 - Fax +39 0331 579479
E-mail: info@cdautomation.com - Web: www.cdautomation.com

Declare that the product / Dichiaro che il prodotto:

REVO RTL06RS-0 - REVO RTL09RS-0

PRODUCT DESCRIPTION: Temperature Controller
SCOPE OF APPLICATION: Thermal control process
DESCRIZIONE DEL PRODOTTO: Termoregolatore
UTILIZZO: Controllo processi termici

The company declares herewith on own responsibility that the above-mentioned products meet the requirements of the EMC and hazardous substances directives. Conformity has been verified with reference to the following Harmonized Standards.

Con la presente l'azienda dichiara sotto la propria responsabilità che il prodotto sopracitato soddisfa per progettazione e costruzione i requisiti della Direttiva "compatibilità elettromagnetica" e "sostanze pericolose". La conformità è stata verificata con l'ausilio delle seguenti Norme Armonizzate se applicabili:

EN 61000-6-2 (2019-06)

EN 60947-1

EN 60947-4-3

EN 61326-1 Group 1 Class A emissions / Emissioni Gruppo 1 Classe A

EN IEC 61000-6-2 Industrial Immunity / Immunità Industriale

CDAutomation declares that the products above mentioned are conforming to the directive
Low Voltage Directive updated 2014/35/EU

CDAutomation dichiara che i prodotti sopra menzionati sono conformi alla direttiva
Bassa Tensione (low Voltage) EMC directive updated 2014/30/EU,

Issued on: 18/04/2022
Data di emissione: 18/04/2022

Amministratore Unico e
Legale Rappresentante
Simone Brizzi





Declaration of conformity

Declaration of conformity - Dichiarazione di Conformità



PRODUCT MANUFACTURER / PRODUTTORE:



CD Automation S.R.L.
Controllers, Drives & Automation

Via Picasso, 34/36 - 20025 Legnano (MI)- Italy
P.I. 08925720156 -Tel. +39 0331 577479 - Fax +39 0331 579479
E-mail: info@cdautomation.com - Web: www.cdautomation.com

Declare that the product / Dichiaro che il prodotto:

REVO RTL06RS-0 - REVO RTL09RS-0

PRODUCT DESCRIPTION: Temperature Controller
SCOPE OF APPLICATION: Thermal control process
DESCRIZIONE DEL PRODOTTO: Termoregolatore
UTILIZZO: Controllo processi termici

The company declares herewith on own responsibility that the above-mentioned products meet the requirements of the EMC and hazardous substances directives. Conformity has been verified with reference to the following Harmonized Standards.

Con la presente l'azienda dichiara sotto la propria responsabilità che il prodotto sopracitato soddisfa per progettazione e costruzione i requisiti della Direttiva "compatibilità elettromagnetica" e "sostanze pericolose". La conformità è stata verificata con l'ausilio delle seguenti Norme Armonizzate se applicabili:

EN 61000-6-2 (2019-06)

EN 60947-1

EN 60947-4-3

EN 61326-1 Group 1 Class A emissions / Emissioni Gruppo 1 Classe A

EN IEC 61000-6-2 Industrial Immunity / Immunità Industriale

CDAutomation declares that the products above mentioned are conforming to the directive
Low Voltage Directive updated 2014/35/EU

CDAutomation dichiara che i prodotti sopra menzionati sono conformi alla direttiva
Bassa Tensione (low Voltage) EMC directive updated 2014/30/EU,

Issued on: 18/04/2022

Data di emissione: 18/04/2022





Amministratore Unico e
Legale Rappresentante
Simone Brizzi

Important warnings for safety

This chapter contains important information for the safety. The not observance of these instructions may result in serious personal injury or death and can cause serious damages to the Thyristor unit and to the components system included.

The installation should be performed by qualified persons.

In the manual are used symbols to give more evidence at the notes of safety and operativity for the attention for the user:



	This icon is present in all the operational procedures where the Improper operation may result in serious personal injury or death by Electrical Shock Hazard Symbol (a lightning bolt in a triangle) precedes an electric shock hazard CAUTION or WARNING safety statement.
	Warning or Hazard that needs further explanation than the label on unit can provide. Consult User's Guide for further information.
	Unit is compliant with European Union directives. See Declaration of Conformity for further details on Directives and Standards used for Compliance.
	ESD Sensitive product, use proper grounding and handling techniques when installing or servicing product.
	Do not throw in trash, use proper recycling techniques or consult manufacturer for proper disposal.









A **"NOTE"** marks a short message to alert you to an important detail.

A **"CAUTION"** safety alert appears with information that is important for protecting your equipment and performance. Be especially careful to read and follow all cautions that apply to your application.

A **"WARNING"** safety alert appears with information that is important for protecting you, others and equipment from damage. Pay very close attention to all warnings that apply to your application.

Safety notes

-  **WARNING!** Risk of Fire and Electric Shock. This product is "Open Type Process Control Equipment". It must be mounted in an enclosure that does not allow fire to escape externally.
-  **WARNING!** If the output relays are used past their life expectancy, contact fusing or burning may occasionally occur. Always consider the application conditions and use the output relays within their rated load and electrical life expectancy. The life expectancy of output relays varies considerably with the output load and switching conditions.
-  **WARNING!** To avoid damage to property and equipment, injury and loss of life, adhere to applicable electrical codes and standard wiring practices when installing and operating this product. Failure to do so could result in damage, injury and death.

-  **WARNING!** All service including inspection, installation, wiring, maintenance, troubleshooting, fuse or other user serviceable component replacement must be performed only by properly qualified personnel. Service personnel must read this manual before proceeding with work. While service is being performed unqualified personnel should not work on the unit or be allowed in the immediate vicinity.
-  **WARNING!** Do not use in aerospace or nuclear applications.
-  **WARNING!** The device's protection rating is IP20 with all covers installed and closed. It must be installed in an enclosure that provides all the necessary additional protections appropriate for the environment and application.
-  **CAUTION:** Devices shall be supplied with limited energy according to UL 61010-1 3rd Ed, section 9.4 or LPS in conformance with UL 60950-1 or SELV in conformance with UL 60950-1 or Class 2 in compliance with UL 1310 or UL 1585.
-  **CAUTION:** A malfunction in the Digital Controller may occasionally make control operations impossible or prevent alarm outputs, resulting in property damage. To maintain safety in the event of malfunction of the Digital Controller, take appropriate safety measures, such as installing a monitoring device on a separate line.
-  **CAUTION:** To avoid compromising the insulation, do not bend wire or other components beyond their bend radius specifications.
-  **CAUTION:** Protect the device from high temperature, humidity and vibrations.
-  **CAUTION:** Install an appropriately sized RC filter across contactor coils, relays and other inductive loads.
-  **NOTE:** Provide a local disconnect to isolate the device for servicing.

Precautions for safe use

Be sure to observe the following precautions to prevent operation failure, malfunction, or adverse affects on the performance and functions of the product. Not doing so may occasionally result in unexpected events. Do not handle the Digital Controller in ways that exceed the ratings.

- The product is designed for indoor use only. Do not use or store the product outdoors or in any of the following places:
 - Places directly subject to heat radiated from heating equipment.
 - Places subject to splashing liquid or oil atmosphere.
 - Places subject to direct sunlight.
 - Places subject to dust or corrosive gas (in particular, sulfide gas and ammonia gas).
 - Places subject to intense temperature change.
 - Places subject to icing and condensation.
 - Places subject to vibration and large shocks.
- Installing two or more controllers in close proximity might lead to increased internal temperature and this might shorten the life cycle of electronic components. It is strongly recommended to install cooling fans or other air-conditioning devices inside the control cabinet.
- Always check the terminal names and polarity and be sure to wire properly. Do not wire the terminals that are not used.
- To avoid inductive noise, keep the controller wiring away from power cables that carry high voltages or large currents. Also, do not wire power lines together with or parallel to Digital Controller wiring. Using shielded cables and using separate conduits or ducts is recommended. Attach a surge suppressor or noise filter to peripheral devices that generate noise (in particular motors, transformers, solenoids, magnetic coils or other equipment that have an inductance component). When a noise filter is used at the power supply, first check the voltage or current, and attach the noise filter as close as possible to the Digital Controller. Allow as much space as possible between the Digital Controller and devices that generate powerful high frequencies (high-frequency welders, high-frequency sewing machines, etc.) or surge.
- A switch or circuit breaker must be provided close to device. The switch or circuit breaker must be within easy reach of the operator, and must be marked as a disconnecting means for the controller.
- The device must be protected by a fuse 1 A (cl. 9.6.2).
- Wipe off any dirt from the Digital Controller with a soft dry cloth. Never use thinners, benzine, alcohol, or any cleaners that contain these or other organic solvents. Deformation or discoloration may occur.
- The number of non-volatile memory write operations is limited. Therefore, use EEprom write mode when frequently overwriting data, e.g.: through communication.

Environmental policy / WEEE

Do not dispose electric tools together with household waste material.

According to European Directive 2012/19/EU on waste electrical and electronic equipment and its implementation in accordance with national law, electric tools that have reached the end of their life must be collected separately and returned to an environmentally compatible recycling facility.



Maintenance

To maintain proper cooling, the user must clean the unit's protective grille. The frequency of these operations depends on the local air pollution.

Also check periodically that the screws of the power and control terminals are tightened correctly (see Connection Diagram).

Warranty condition

Producer gives a 12 months warranty to its products.

The warranty is limited to repairing and parts substitution in our factory and does exclude products not properly used and fuses.

Warranty does not include products with serial numbers deleted. The faulty product should be shipped to Producer at customer's cost and our Service will evaluate if product is under warranty terms.

Substituted parts remain of Producer property.



The manufacturer shall under no circumstances be held liable for any damage to persons or property resulting from tampering, incorrect or improper use or in any case not in accordance with the characteristics of the product and the instructions contained in this manual.

[General terms and conditions](#)



Return Material Authorization (RMA)

Customers wishing to return any items, whether they are incorrectly supplied, faulty or damaged in transit, must first complete a Return Material Authorisation (RMA) form to obtain an RMA number from the Service Department.

A full repair service is available for customers. Prior to submitting the RMA form and returning products, customers are recommended to contact the technical support team to determine whether the issue can be resolved with telephone support.

How the RMA service works

The RMA form and details are available on our web sites:

<https://www.cdautomation.com/rma-english-version/>

When completing the RMA form, please be as specific as possible about the problem, including any pertinent application details. The more information given, the more quickly and more thoroughly the problem can be solved. The minimum information required is:

1. The Full Model Number
2. Quantity of units being returned
3. The units Serial Number(s)
4. A description of the problem ("faulty" or "unknown" is not sufficient).



Summary

- Declaration of conformity. 2
- Important warnings for safety 4
 - Precautions for safe use. 6
 - Environmental policy / WEEE. 6
- Maintenance 7
- 1 Introduction. 10
 - 1.1 Main features of the control board. 11
- 2 Configurator software 12
 - 2.1 Connection with Controllers for Configuration 12
- 3 Identification and Order Code 13
 - 3.1 Identification of the unit 13
- 4 Technical Specifications. 15
 - 4.1 General features 15
 - 4.2 Input 15
 - 4.3 Outputs 15
 - 4.4 Current transformer input 15
 - Current transformer type 1000 coils (50/0.05A). 15
 - 4.5 Digital output 15
 - 4.6 Control 16
 - 4.7 Alarms 16
 - 4.8 Physical characteristics 16
 - 4.9 Environmental installation conditions 16
- 5 Installation 17
 - 5.1 Dimensions and weight 18
 - 5.2 Fixing holes 18
- 6 Wiring instructions 19
 - 6.1 Terminals diagram 20
 - 6.2 Command terminals. 21
 - 6.3 Multiple connection 22
 - 6.4 Voltage supply 22

- 6.5 Thermocouple input. 22
- 6.6 Analog input. 23
- 6.7 Digital input 23
- 6.8 Relay output. 23
- 6.9 SSR outputs 24
- Also check the correct polarity of connections. 24
- 6.10 Wiring example with single-phase network. 24
- 7 Modbus/TCP connection 25**
 - 7.1 Characteristics. 25
 - 7.2 General description 25
 - 7.3 Instructions for use. 25
 - 7.4 Light signalling 25
 - 7.5 Addressing of boards 26
- 8 Configurator software 27**
 - 8.1 Introduction 27
 - 8.2 Locating the control loop 28
 - 8.2 Connecting with the controller. 29
 - 8.3 Using the configurator 30
- 9 Configuration parameter list 43**
 - 9.1 Analog Input 43
 - 9.2 SSR control outputs 46
 - 9.3 Autotuning and PID 48
 - 9.4 Alarms. 52
 - 9.5 Relays Digital Outputs 55
 - 9.6 Digital Input 56
 - 9.7 Soft Start 57
 - 9.8 Input with Current Transformer. 58
 - 9.9 Serial RS485 Modbus RTU 59
 - 9.10 Data exchange table 60
- 10 Inputs and outputs 67**
 - 10.1 Analog inputs 67
 - 10.2 Digital input 68
 - 10.3 Current transformer input CT 69
 - 10.4 Relay output 70
 - 10.5 SSR outputs 71

1

Introduction

REVO RT Loop is a multi-zone PID controller for modular rear panel installation



Each basic module is capable of managing three single (heat) or dual (heat/cool) zones. Heating is managed via logic outputs connected to external drive units, that allow **the control of electric heaters**.

- RT Loop can work independently or connected with a PLC. It has been designed to replace traditional panel-mount controllers or to replace PLC PID loops.
- RT Loop consists of one or more control modules, each equipped with communication ports. Each module can manage 3 to 9 loops, depending on the number of control cards contained within it, with the possibility of combining different types of modules.
- With RT Loop, 24 loops takes up only 348mm in width.
- Via integrated communication ports or external termination modules, the most popular communication protocols are supported: ModBus RTU, ProfiNet, ModBus TCP, Ethernet IP.
- Up to 24 zones per branch with Fieldbus or 90 zones with Modbus RTU communication.

1.1 Main features of the control board

The multi-zone RT Loop system has been developed specifically for temperature control using electric heating elements.

It is a modular system, where each module contains one or more 3-loop control boards.

Each control board includes:

- 3 process inputs configurable as thermocouple or analogue.
- 3 SSR outputs for controlling external REVO S static units, for heating control.
- 3 Current sensor inputs for heater break alarm.
- 4 Relays used for alarm or cooling output.
- 1 Relay used for start function.
- 1 Digital input

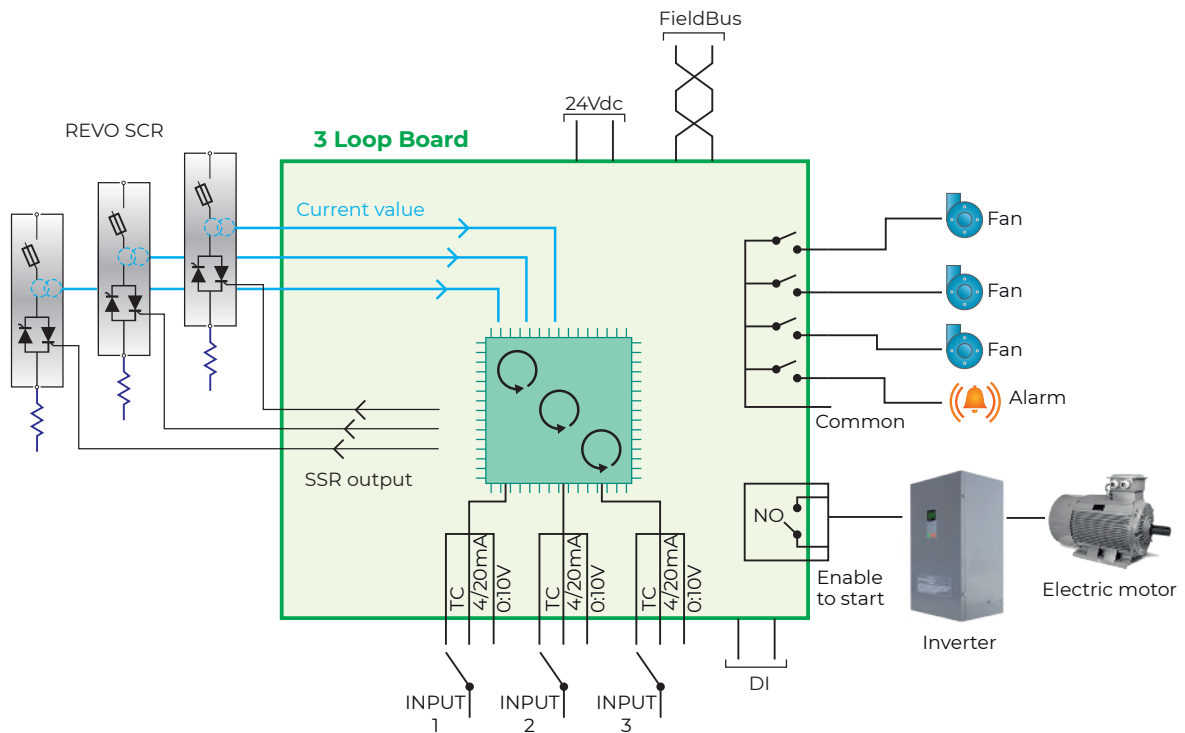
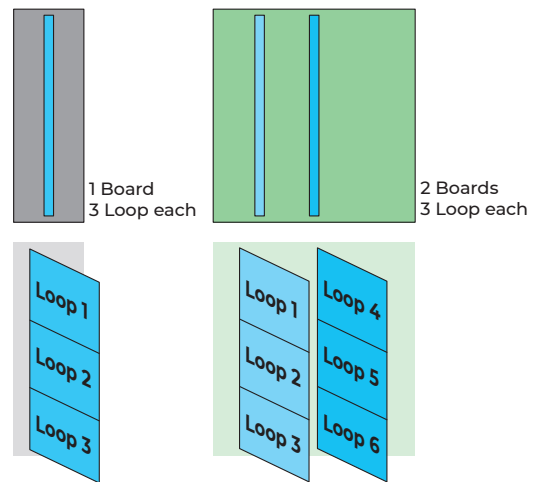

2 Configurator software

The controller configuration software is free of charge and can be downloaded from our website. To install the software, start the programme and follow the instructions on the screen. Run the configuration software and set the correct serial port number via the menu setting: serial port number.

To connect the unit to the PC, the micro USB 2.0 Modbus RTU cable must be used.

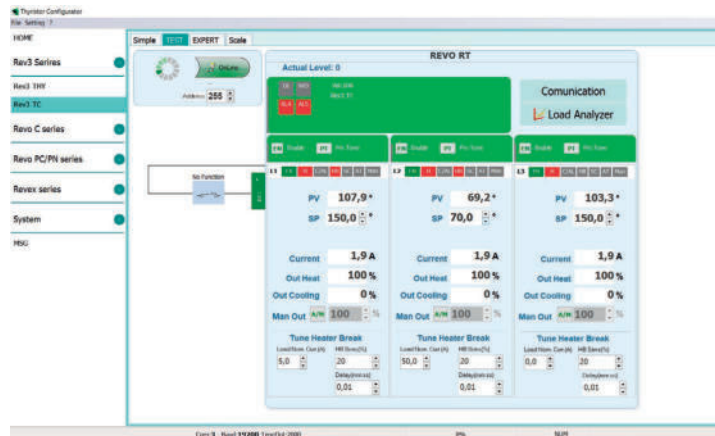

Configurator Software download link:

https://www.cdautomation.com/wp-content/uploads/ThyristorConfigurator_ver6.zip

2.1 Connection with Controllers for Configuration

A micro USB port, located on the front of the boards inside the controller, allows the board to be connected to a computer via a simple micro USB cable. The controller electronics are powered by a USB cable, so it is possible to inspect them before applying power.



Attention! The power of the USB port is limited and not designed to power industrial boards, so it can only power the essential parts of the electronics. For complete control, it is necessary to power the controller's auxiliaries

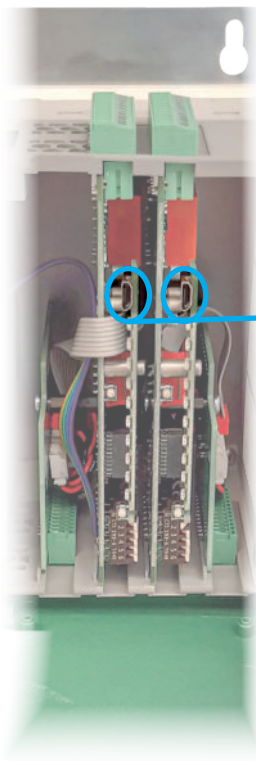

Micro USB

The USB connection requires a driver to function properly. The setup software installer will already install the correct driver, however, you can also find it on our website.

3

Identification and Order Code

3.1 Identification of the unit



Attention: Before to install, make sure that the unit have not damages. If the product has a fault, please contact the dealer from which you purchased the product.

The identification label give all the information regarding the factory settings of the unit, this label is on the unit, like represented in figure.

Verify that the product is the same thing as ordered.

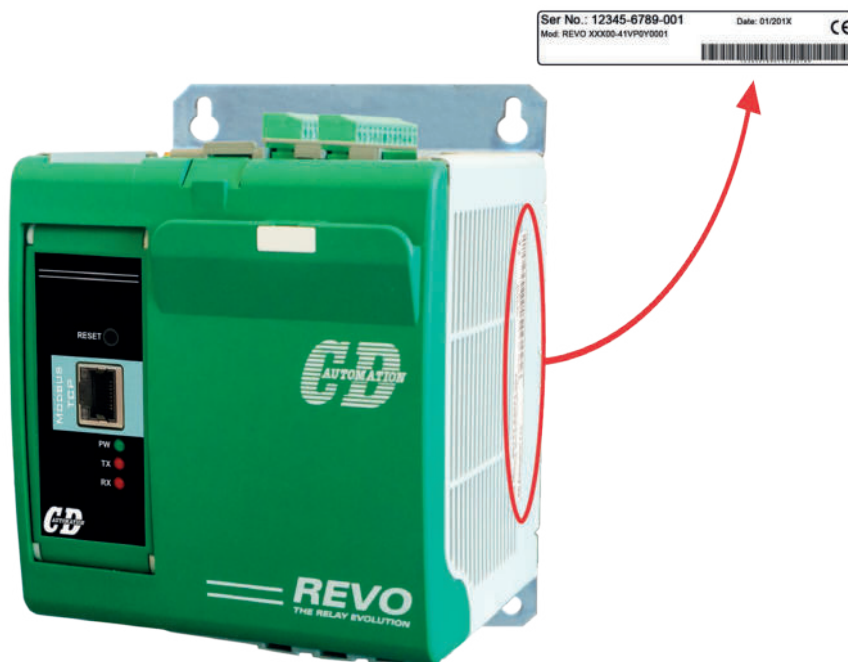

3.2 Order Code

	1	2	3	4	5	6	7		8	9	10	11	12	13	14	15	16
ORDER CODE	R	T	L	0	-	R	S	-	-	0	0	0	0	0	0	-	1

N° LOOP	4	5
descrizione	cod.	
3 Loop	0	3
6 Loop	0	6

TIPO	6
descrizione	cod.
Regolatore SSR Output, CT Input, Relay output	R

DIMENSIONI	7
descrizione	cod.
Standard Size	S

COMUNICAZIONE	8
descrizione	cod.
Ethernet Modbus TCP	1
Ethernet IP (<i>disponibile per progetti già esistenti, per nuovi progetti attendere 2023</i>)	4

ALTRO	9 10 11 12 13
descrizione	cod.
PID Regulator, temperature controller	0

APPROVAZIONI	14
descrizione	cod.
CE EMC per il mercato europeo	0

MANUALE	15
descrizione	cod.
Nessuno	0
Italiano	1
Inglese	2
Tedesco	3
Francese	4

VERSIONE	16
descrizione	cod.
Standard	1

Example:

N° 24 zones with Modbus TCP

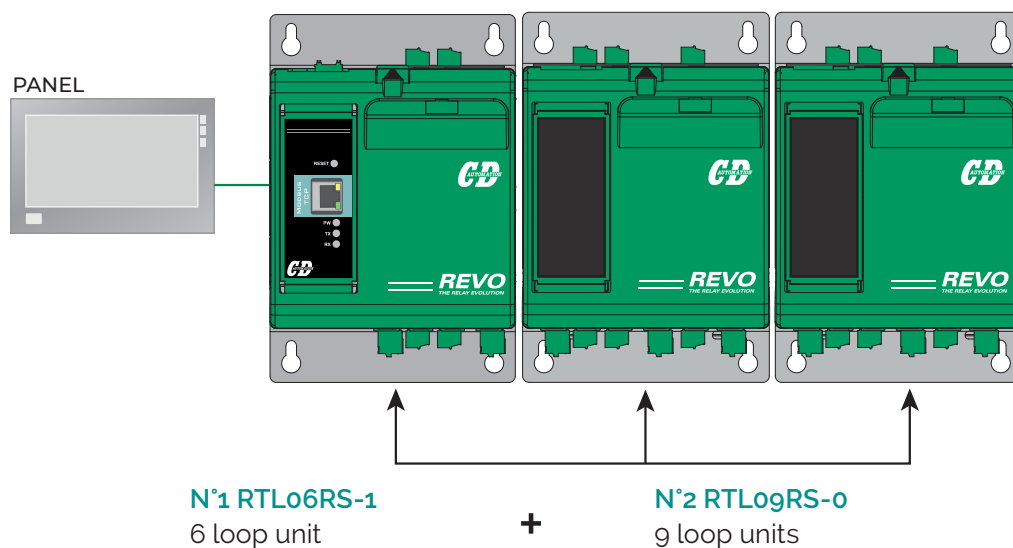

4

Technical Specifications

4.1 General features

Power consumption:

Auxiliary voltage 24Vdc 180 mA max

4.2 Input

software configurables

Input n°: 3

Resolution 16Bit

Thermocouple

Type: K, S, R, J, T, E, N, B with automatic joint compensation

Tolerance +/- 0,2% FS

Cold junction accuracy +/- 0,1 °C/°C

V/mA

Type: 0-1V, 0-5V, 0-10V, 0-20mA, 4-20mA, 0-60mV

Impedence: 0-10 V: > 110 KΩ

0-20 mA: < 5 Ω

0-60 mV: > 1 MΩ

4.3 Outputs

Relay

Function: Cooling, temperature alarms, system alarms, system signals

DO 1,2,3: 230Vac / 1A resistive load

DO4: 230Vac / 1A resistive load

DO5: 24V / 1A

SSR

Function: Heating

Out 1,2,3: 12V 25mA

4.4 Current transformer input

Input measuring range 0-200A

12 Bit resolution

Current transformer type 1000 coils (50/0.05A)

4.5 Digital output

Function: Enabling, Alarm reset, External alarm

Type: Free Voltage or 12Vdc

4.6 Control

Control algorithm:	ON-OFF with hysteresis, P, PI, PID, PD with proportional time
Proportional band:	0÷9999°C or °F
Integral time:	0,0÷999,9 sec (0 = OFF)
Derivative time:	0,0÷999,9 sec (0 = OFF)
Control type:	Manual, Auto

4.7 Alarms

3 configurable alarms, 1 cumulative alarm

4.8 Physical characteristics

Protection:	IP 20
Plastic material:	Polimeric V2

4.9 Environmental installation conditions

Ambient temperature	0-40°C (32-104°F) at nominal current. Over 40°C-104°F use the derating curve (max 50°C).
Storage temperature	from -25°C to 70°C from -13°F to 158°F
Installation	Don't install at direct sun light, where there are conductive dust, corrosive gas, vibration or water and also in salty environmental
Altitude	Up to 1000 meter over sea level. For higher altitude reduce the nominal current of 2% for each 100m over 1000m
Humidity	From 5 to 95% without condense and ice
Pollution level	Up to 2nd level ref. IEC 60947-1 6.1.3.2

5 Installation

Before installation, ensure that the unit has not been damaged during transport. In case of damage, notify the carrier immediately. Verify that the product is the same thing as ordered.

If the product has a fault, please contact the dealer from which you purchased it.

The units must be always mounted in vertical position to improve air cooling on heat-sink.

Maintain the minimum distances () in vertical and in horizontal as represented, this area must be free from obstacle (wire, copper bar, plastic channel).

When more unit has mounted inside the cabinet maintain the air circulation like represented in figure without obstacle for the air flow. Is necessary to install a fan to have better air circulation as calculated previously.

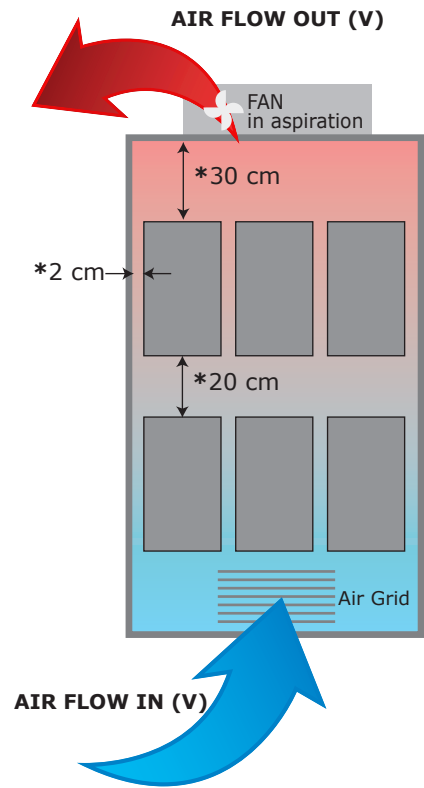

The V Air flow must be equal or more than the value calculated.

If the cabinet fan mounted by the customer have an air flow lower than the correct value the warranty will decay.

5.1 Dimensions and weight

REVO RTL03RS-1
REVO RTL06RS-1

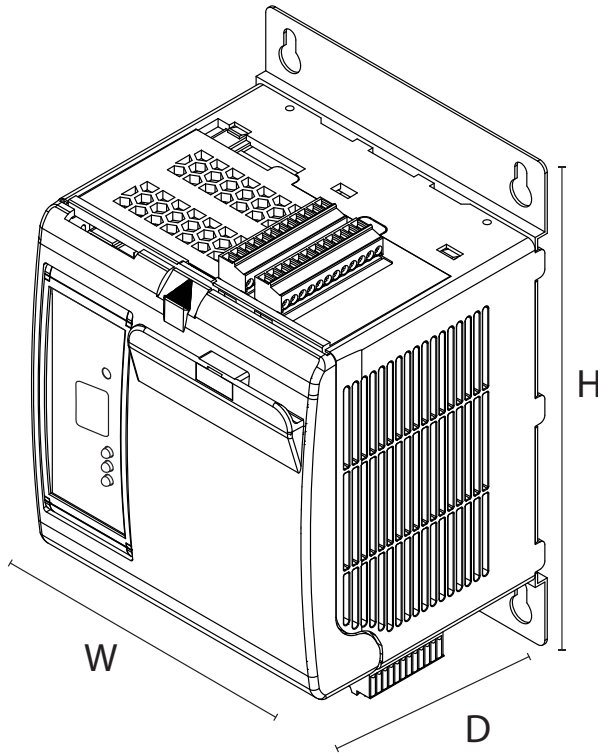

Width (W) (mm): 116
Height (H) (mm): 174
Depth (D) (mm): 103
Weight (kg): 0,8

5.2 Fixing holes

REVORTL03RS-1
REVORTL06RS-1

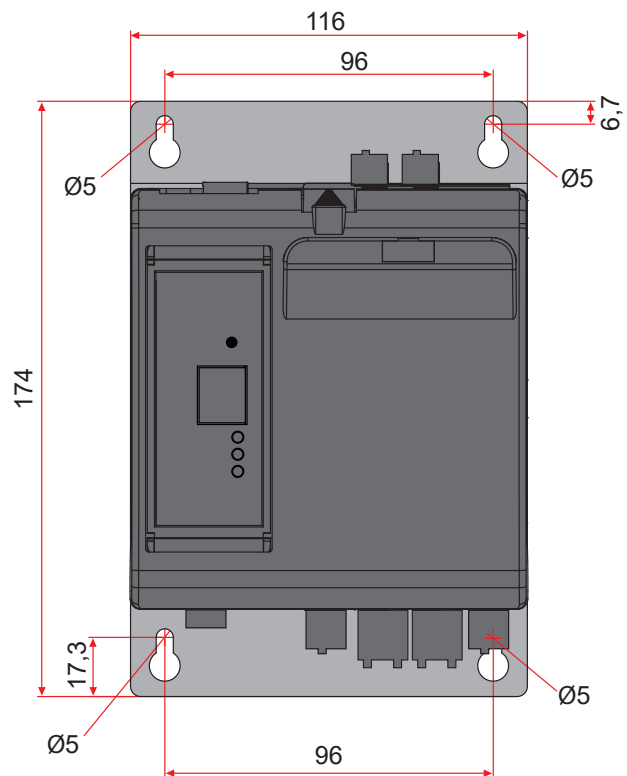

6

Wiring instructions

The unit could be susceptible to interferences lost by near equipments or by the power supply, for this reason in accord to the fundamental practices rules is opportune take some precautions:

- The coil contactor, the relays and other inductive loads must be equipped with opportune RC filter.
- Use shielded bipolar cables for all the input and output signals.
- The signal cables must not be near and parallel to the power cables.
- Local regulations regarding electrical installation should be rigidly observed.

Use 90°C copper cables.

Cable dimensions of the Command Terminals 0.5 mm² (AWG 18)



Warning: Before connecting or disconnecting the unit check that power and control cables are isolated from voltage sources.

6.1 Terminals diagram

REVO RTLO6RS-1



Warning: Before connecting or disconnecting the unit check that power and control cables are isolated from voltage sources.

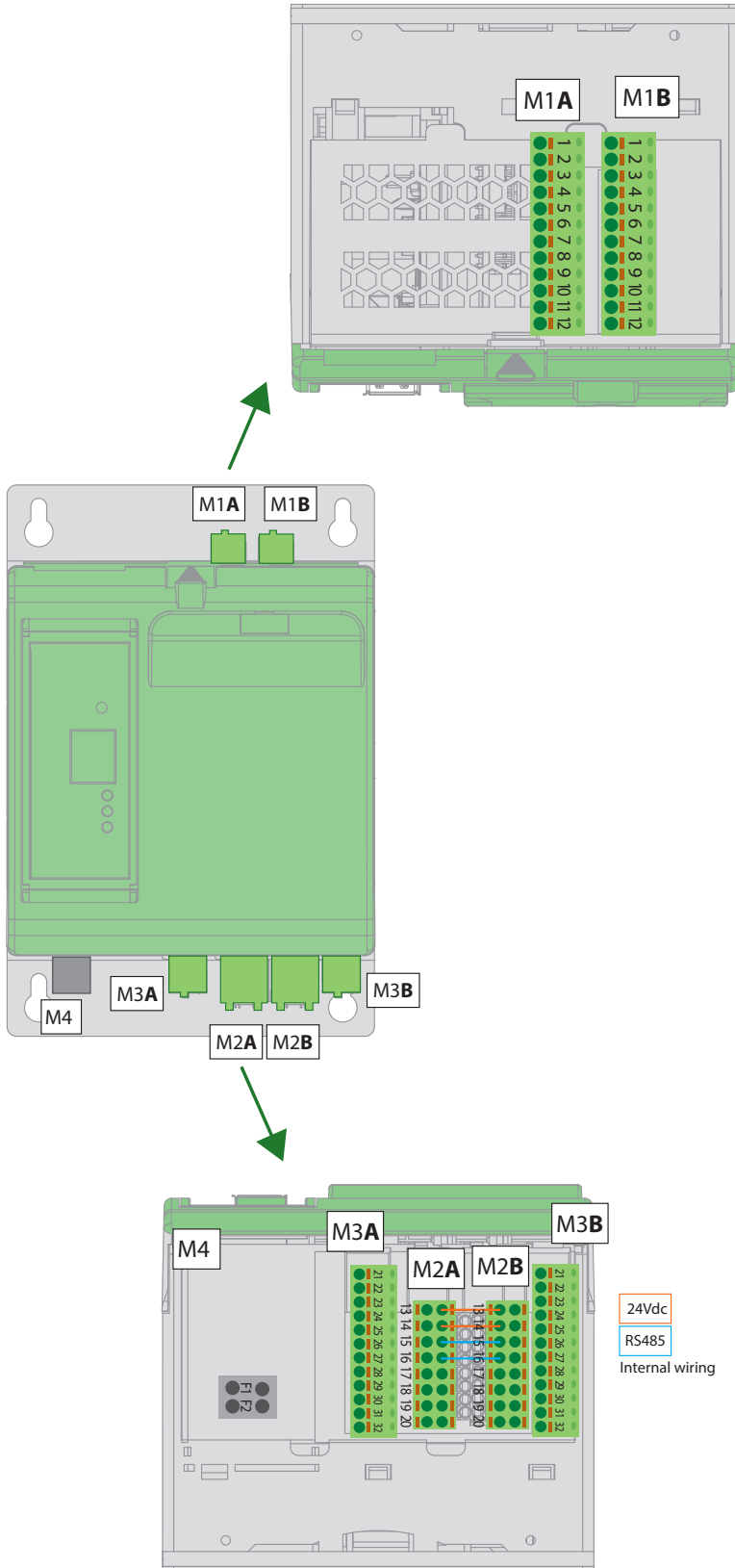

Channels 1-2-3

M1A

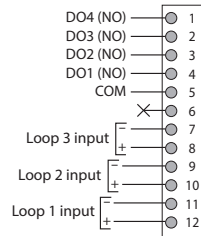

Channels 4-5-6

M1B

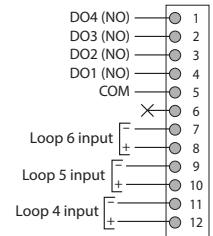

M2A

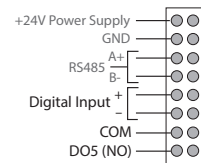

M2B

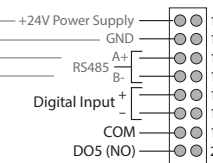

M3A

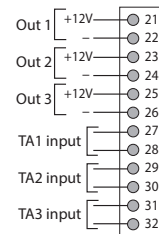

M3B

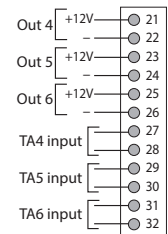

M4



6.2 Command terminals



Warning: Before connecting or disconnecting the unit check that power and control cables are isolated from voltage sources.

Terminal M1: "A" for channels 1-2-3, "B"for channels4-5-6 etc

Terminal	Description
1	Digital output 4 - DO4 (NO)
2	Digital output 3 - DO3 (NO)
3	Digital output 2 - DO2 (NO)
4	Digital output 1 - DO1 (NO)
5	COM - Common Digital Output (C)
6	not connected
7	- Input 3: Loop 3
8	+ Input 3: Loop 3
9	- Input 2: Loop 2
10	+ Input 2: Loop 2
11	- Input 1: Loop 1
12	+ Input 1: Loop 1

Terminal M2: "A" for channels 1-2-3, "B" for channels 4-5-6 etc

Terminal	Description
13	Internal supply + 24Vdc
14	Internal supply - 0Vdc (GND)
15	RS485 A+
16	RS485 B-
17	+ Digital Input
18	- Digital Input
19	COM - Common Digital Output (C)
20	Digital Output 5 - DO5 (NO)

internal wiring

Terminal M3: "A" for channels 1-2-3, "B" for channels 4-5-6 etc

Terminal	Description
21	+12V Out 1
22	0v Out 1
23	+12V Out 2
24	0v Out 2
25	+12V Out 3
26	0v Out 3
27	TA 1 input
28	
29	TA2 input
30	
31	TA3 input
32	

Morsettiera M4

Terminal	Description
F1	Supply 0V (GND)
F2	Supply +24Vdc

6.3 Multiple connection

Example of multiple connection between 6-loop module (RTL06RS-1) and 9-loop module (RTL09RS-0)

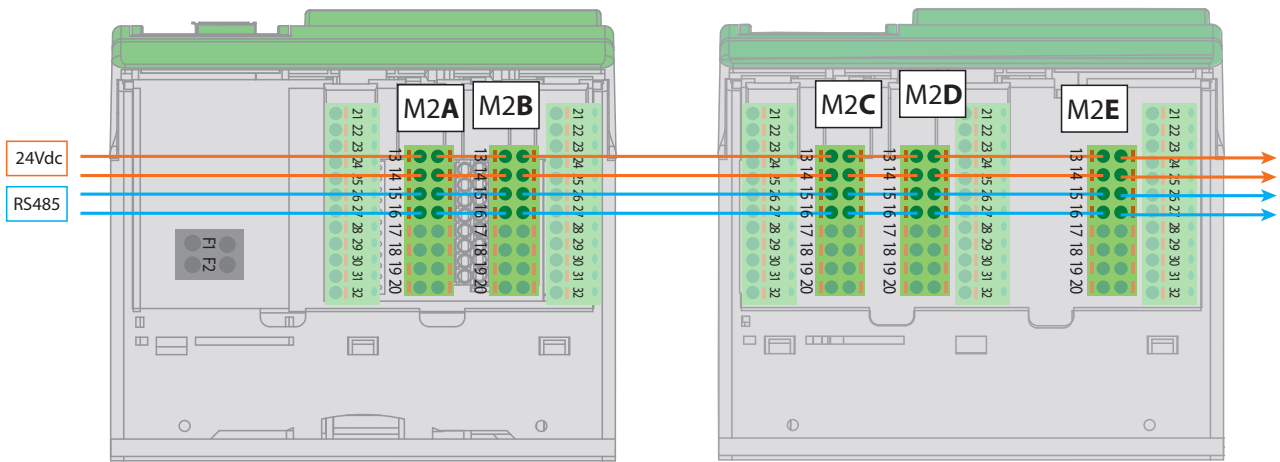

A: Channels 1-2-3 B: Channels 4-5-6 C: Channels 7-8-9 D: Channels 10-11-12 E: Channels 13-14-15

6.4 Voltage supply

The device requires a 24Vdc power supply with a maximum consumption of 180mA.

Protection devices complying with current electrical regulations must be installed on the power supply line.

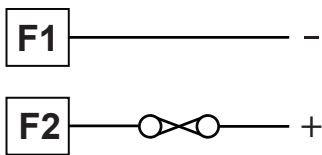

6.5 Thermocouple input

To ensure accurate readings, only use compensated cables that conform to the type of thermocouple used. The use of non-compliant cables may cause unwanted splices and generate parasitic voltages.

Also check the correct polarity of connections.

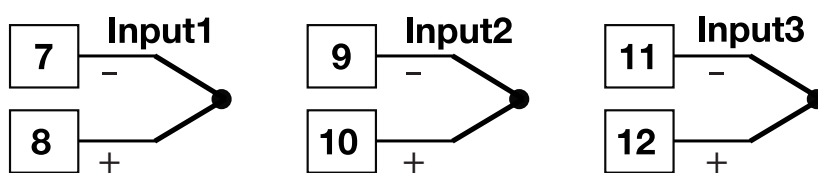

6.6 Analog input

The analogue input can be current (mA) or voltage (V or mV). Also check the correct polarity of connections.

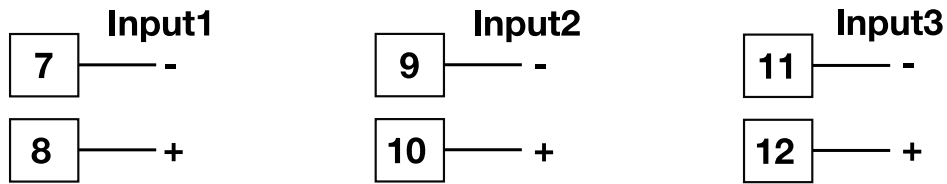

6.7 Digital input

The digital input can be connected with a free contact or with a voltage of 12Vdc.

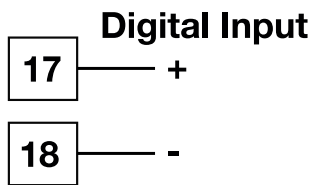

6.8 Relay output

The instrument is equipped with 4 relay outputs with one common side (230Vac 1A with resistive load) and 1 single relay output (24V 1A with resistive load).

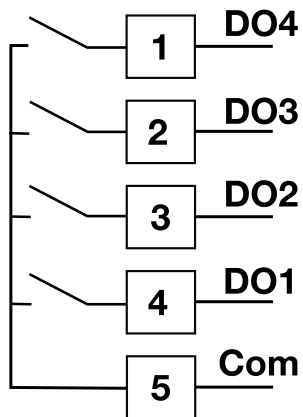

230Vac 1A with resistive load

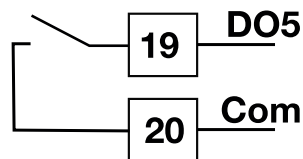

24V 1A with resistive load

6.9 SSR outputs

The instrument is equipped with 3 SSR outputs (12Vcd 25mA)
 Also check the correct polarity of connections.

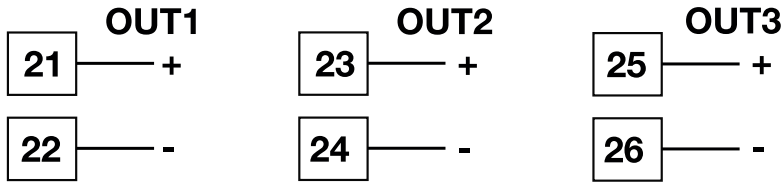

6.10 Wiring example with single-phase network

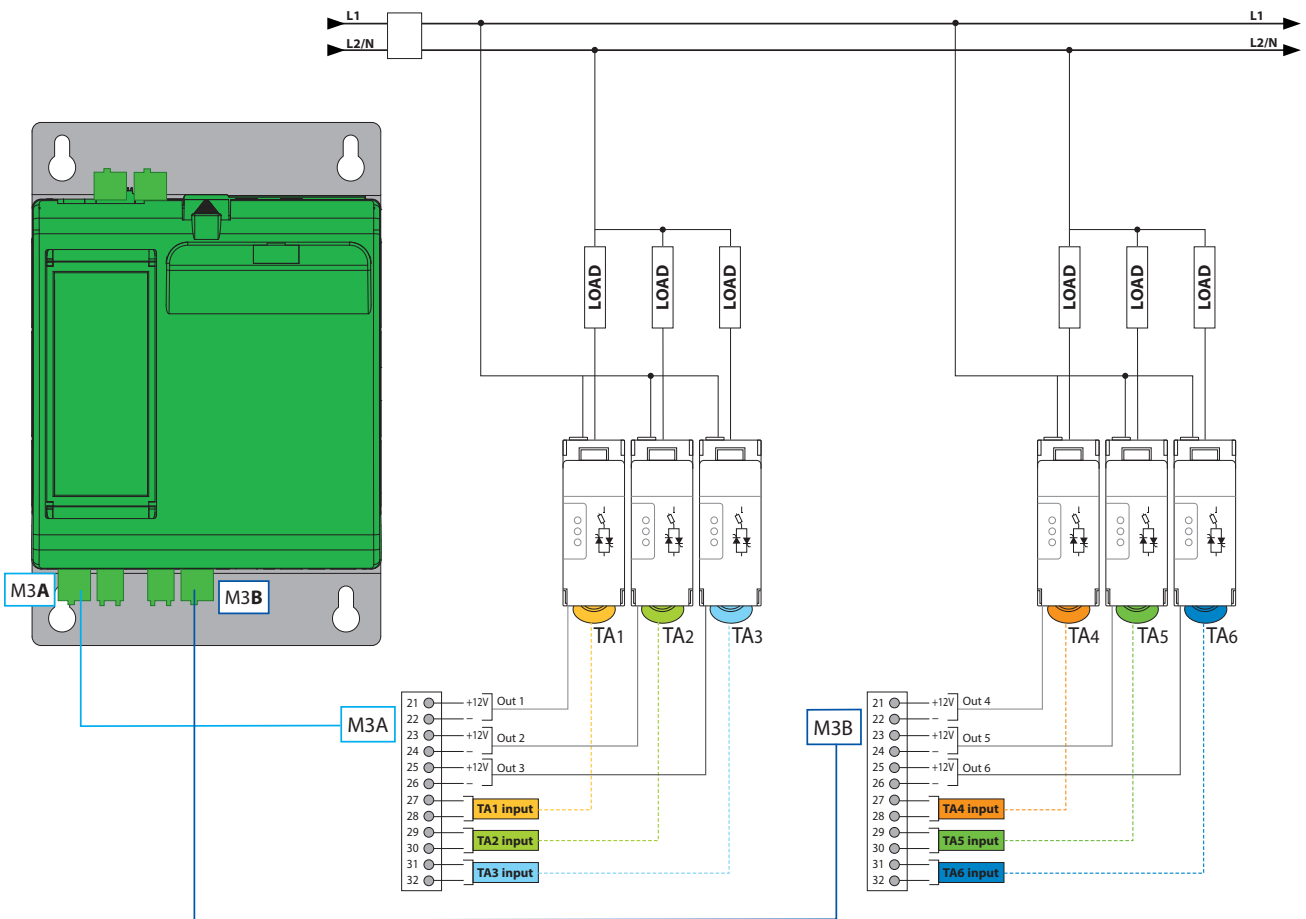

7 Modbus/TCP connection

7.1 Characteristics

Network interface

Ethernet 10/100Base-T, Modbus TCP
 Telnet configuration
 RJ45 connector

7.2 General description

Connection to the Ethernet network with Modbus TCP protocol is possible. Through the Telnet interface, it is possible to configure the Modbus TCP settings (IP address, subnet mask, etc.). LEDs signalling Ethernet activity and data flow on the serial line allow convenient monitoring of system operation. Connection to the Ethernet network is via the RJ45 connector.

7.3 Instructions for use

The device is integrated with most SCADA, HMI or OPC server packages on the market that implement the Modbus TCP protocol. Up to 8 clients can be connected simultaneously. From any remote terminal, network and serial port settings can be configured via the Telnet connection..

Default configuration:

IP address: 192 . 168 . 1 . 100

SubNet Mask: 255 . 255 . 255 . 0

Gateway: 192 . 168 . 1 . 1

Settings RS-485: 38400 , 8 , n , 1

To configure the device via the Telnet interface, send the following command:
"telnet 192.168.1.100 9999"

7.4 Light signalling

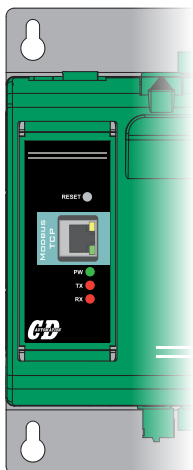

Led	Status	Description
PW	Green ON	Module powered
	OFF	Module NOT powered / Incorrect connection RS-485
RX	Red Blinking	Data received from RS485 network (the blink rate depends on the baud-rate)
	OFF	No reception in progress
TX	Red Blinking	Data received from RS485 network (the blink rate depends on the baud-rate)
	OFF	No reception in progress

7.5 Addressing of boards

Each board is recognisable by a unique address visible on the dipswitches mounted on the board.

Dipswitch

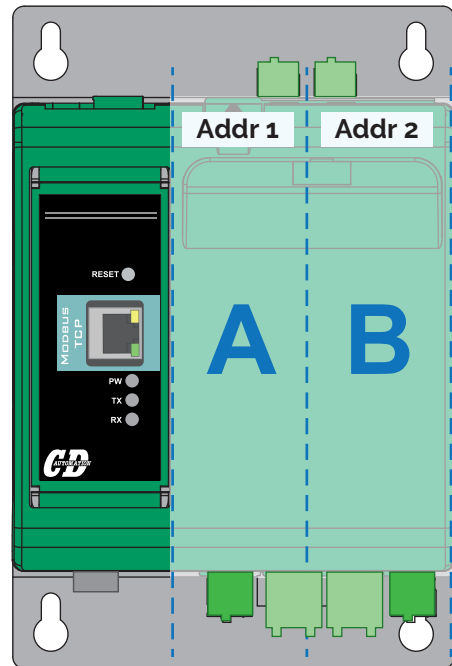
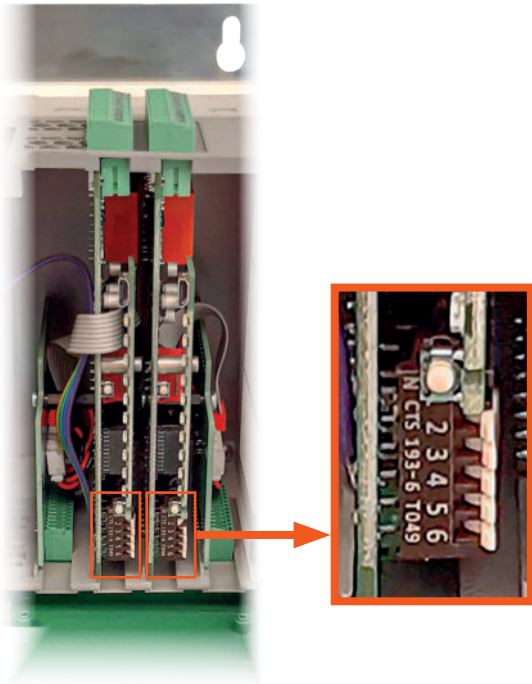

8 Configurator software

8.1 Introduction

The software consists of three basic parts:

- 1) Model selection
- 2) Section dedicated to offline parameter editing

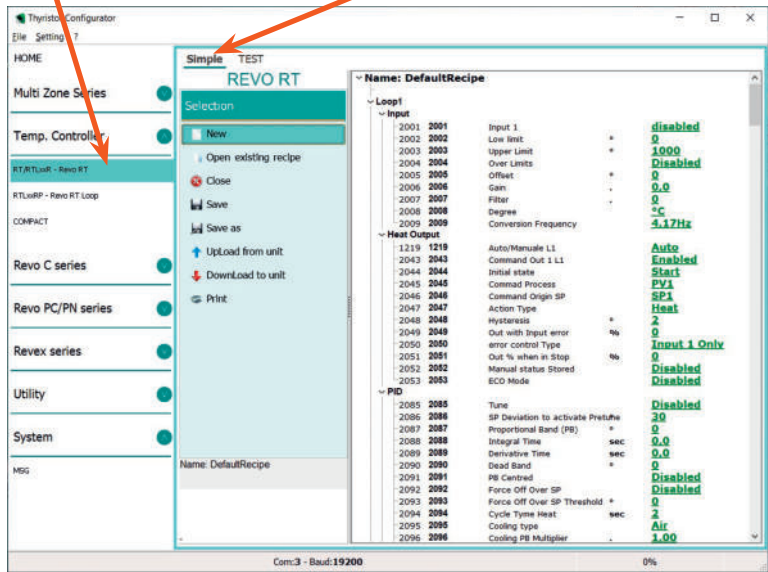

In the "Simple" part, you can do configuration management, called 'recipes', with these functions:

- Make a new recipe
- Open an existing recipe
- Read a recipe from the unit
- Send a recipe to the unit
- Print the recipe

- 3) Section dedicated to online parameter editing

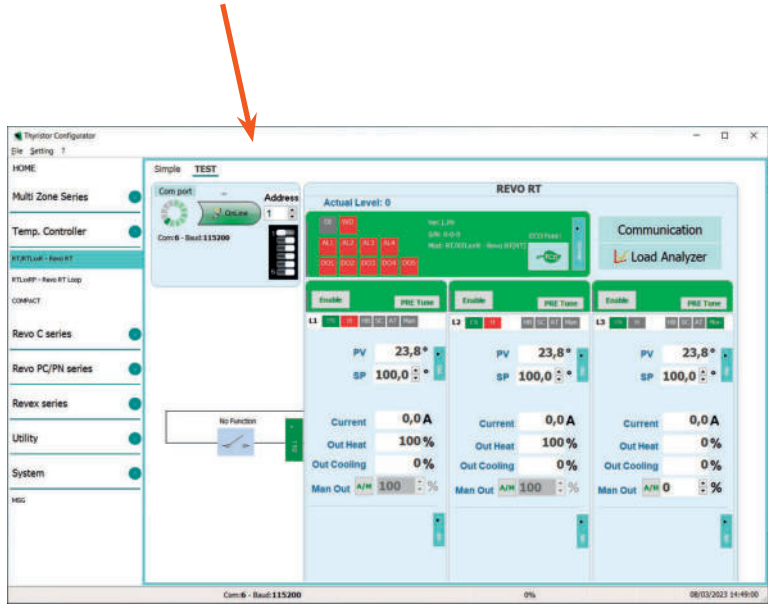

The "test" section is useful for testing or making small configurations. Here it's possible to:

- See all useful application measures
- See all machine and zone status
- Change temperature set
- Change auto/manual control status
- Set values and types of alarms
- Set PID values
- Set values for current diagnostics
- Enable/disable a zone
- Set Serial Parameters
- See processing values in trend form (PV, SP, Out, ...)

By clicking on "LoadAnalyzer", it is possible to graphically view the trend of certain variables, which can be selected for up to 4 at the same time.

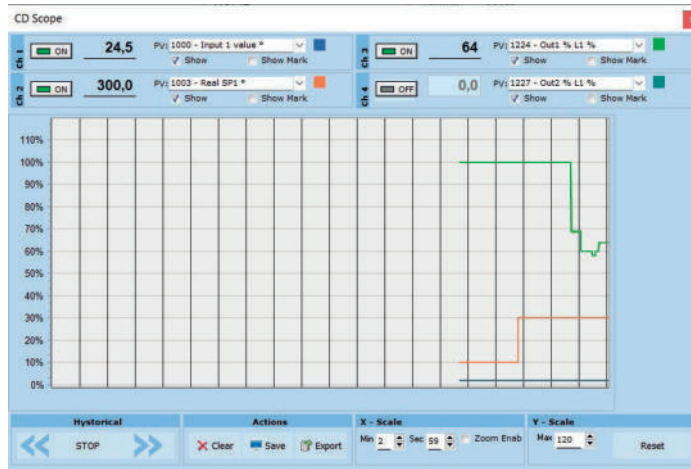

8.2 Locating the control loop

Each control board manages 3 control loops. The configuration software manages 3 control loops at a time. To configure each board, connect to the front USB port on each board and select the configured address (see Chapter 7) or select address 255 (universal address) on the software.

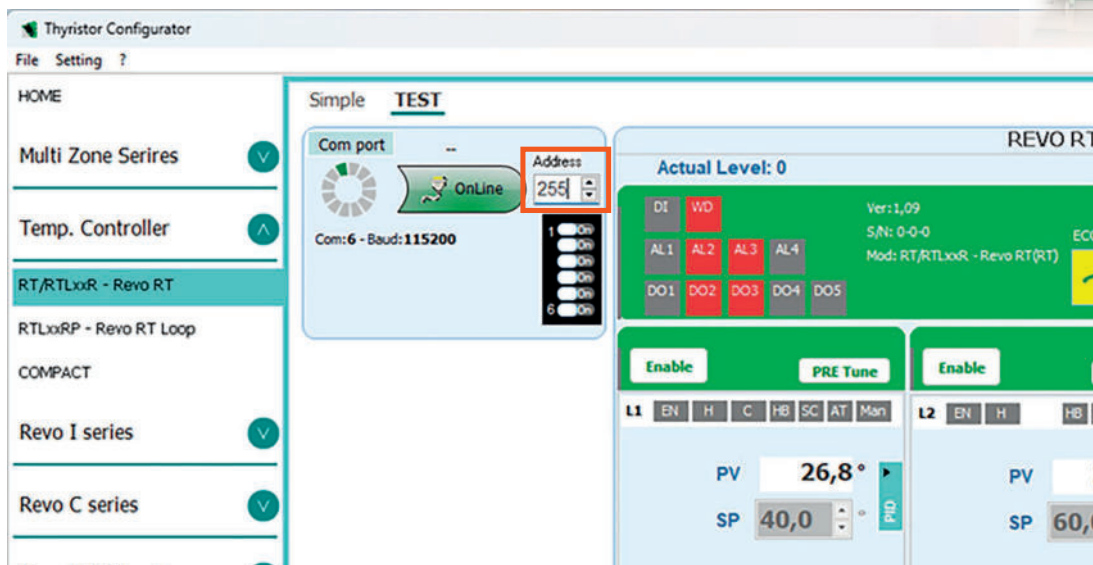
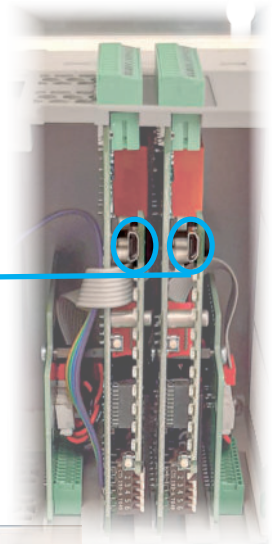

8.2 Connecting with the controller

1) Select connection type

when you use a direct USB connection:

- connect the USB cable between the computer and the Micro USB connector located on the boards inside the controller
- if necessary, wait for the USB driver to be installed.

when you use the RS485 connection:

collegare il regolatore alla porta RS485 del computer. Di solito i PC standard non hanno una porta RS485 quindi è necessario un convertitore USB-RS485.

2) Start the Configurator software

3) Select the model from "Temp. Controller" --> RT/RTLxxR

4) Open the connection settings window from "Setting" -> "Communication"

5) Select "USB"

6) In the "Port" field, select the COM port connected to the power controller (see Note)

7) To verify communication, click "Test"

8) Click "OK"

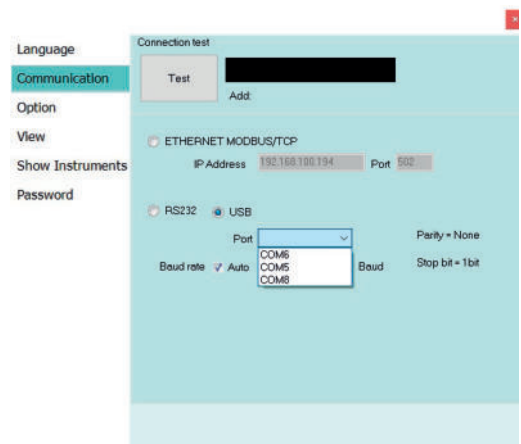

NOTE



Attention! To determine which port is connected to the power controller, you can:

- in Windows® Device Manager under Ports (COM and LPT), searching for the COM port named 'LPC USB VCOM Port (COMx)' where x is the port number.
- In the configuration software:
 - open the programme without connecting the unit and see what COM ports are available in the 'COM Settings' window.
 - close the 'Port' parameter drop-down
 - connect the USB cable to the controller (wait for the USB driver to be installed if necessary), open the dropdown in the 'Port' parameter, see the number added and select it.

8.3 Using the configurator

8.3.1 Making a new recipe

To make a new recipe and open a basic configuration, click on "New".

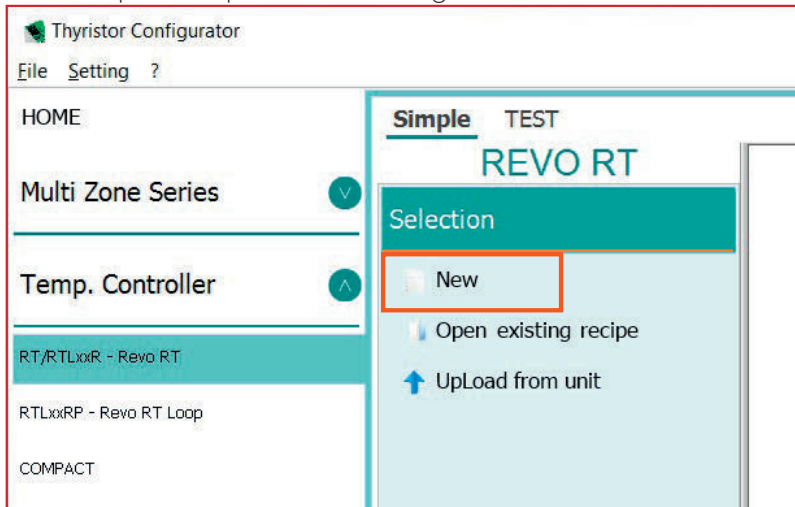

if this window appears:

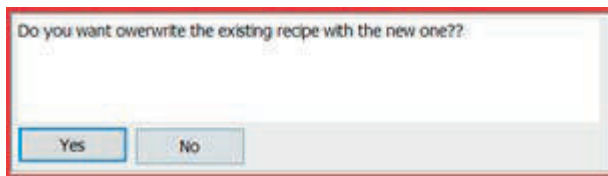

clicking the "yes" button will overwrite the current configuration with the default parameters.

To change the configuration, click on the values in green and select or write the desired value.

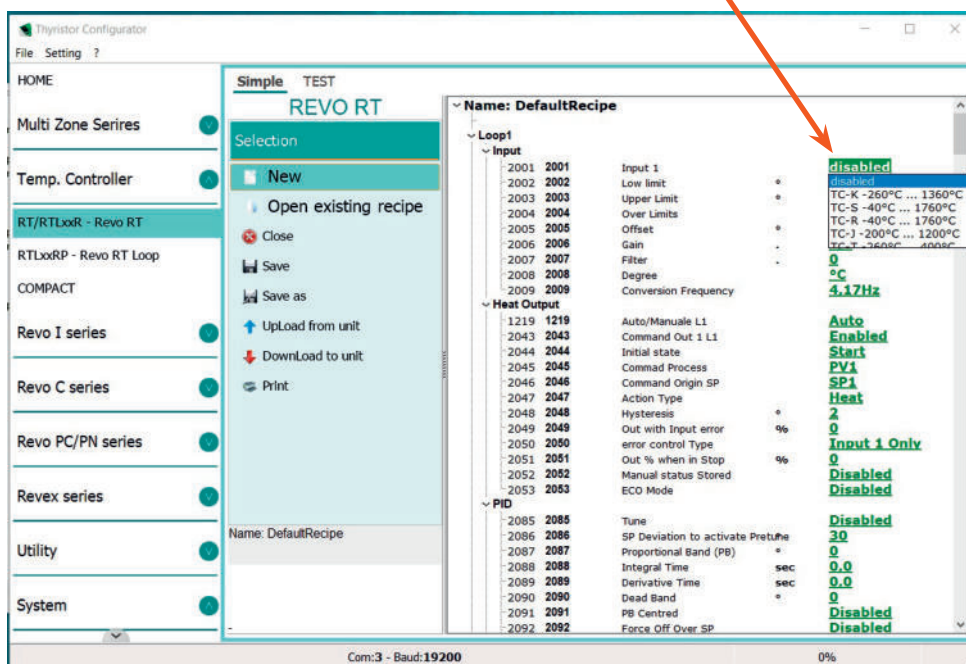

Once the configuration has been opened and edited, it can be saved, printed or sent to the controller.

8.3.2 Open an existing recipe

You can open a previously saved recipe by clicking on **"Open existing recipe"**.

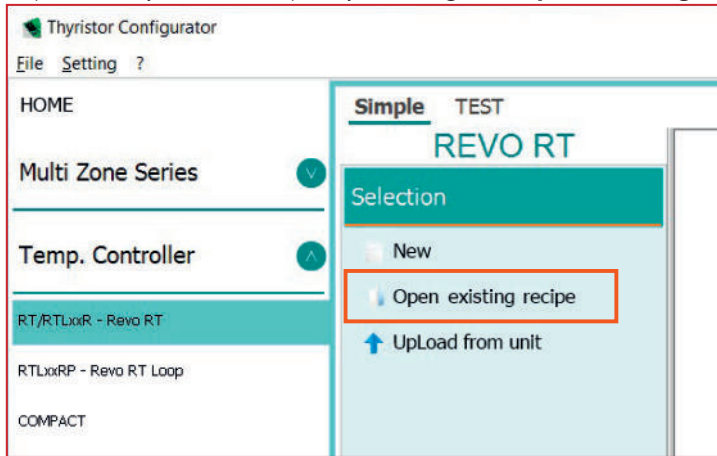

select the file and click on the **"Open"** button, which will open the saved configuration.

8.3.3 Read a recipe from the controller

When you have a board already configured and want to know how it was configured, use the **"Upload"** function.

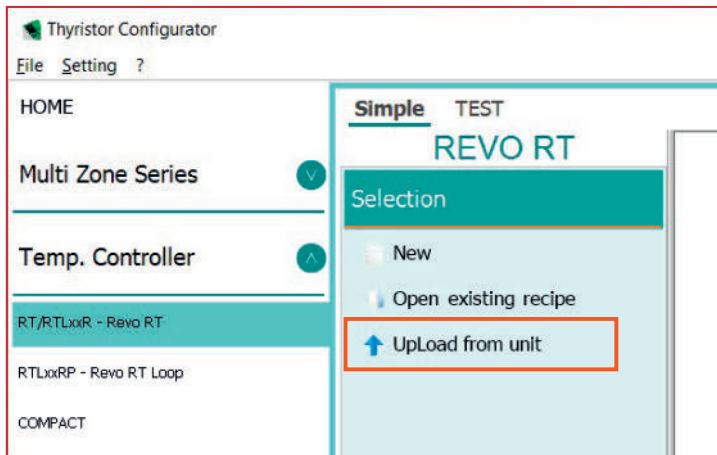

A window will open to start the procedure for reading data from the device



If you know the address, enter it in the Address box or click on "direct" (the latter function is only available from the USB port).

Once the correct address has been set, click on the **"Read"** button to start the reading procedure. This will open the configuration read by the instrument.

8.3.4 Send the recipe to the controller

To send a recipe to the device, click on **"download to unit"**

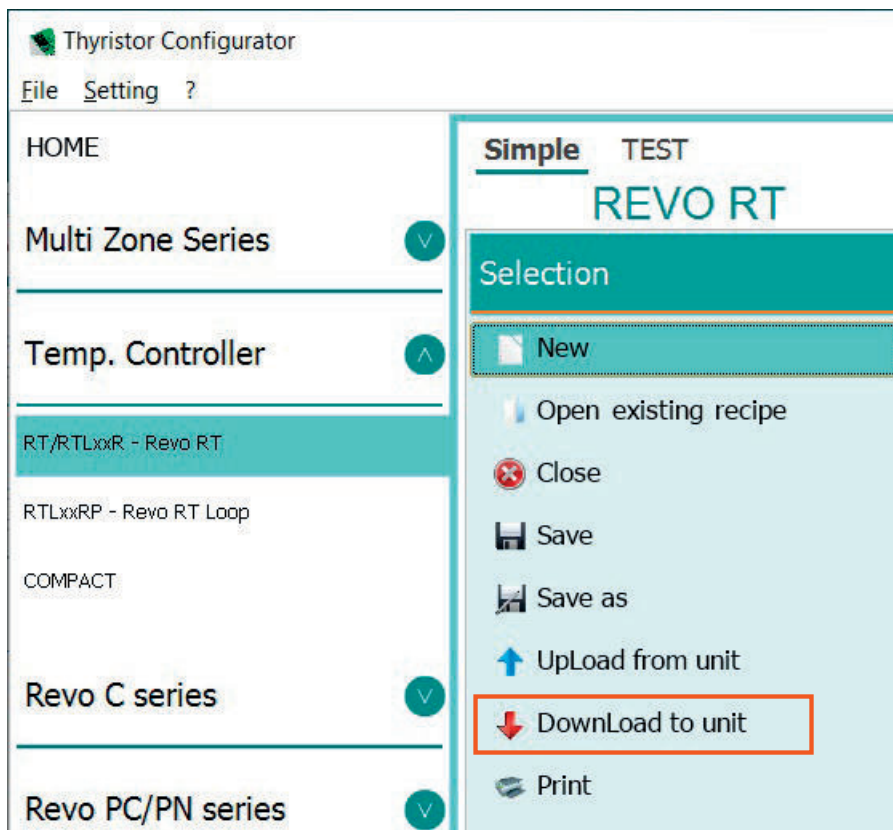

A window will open to start the data writing procedure to the device.

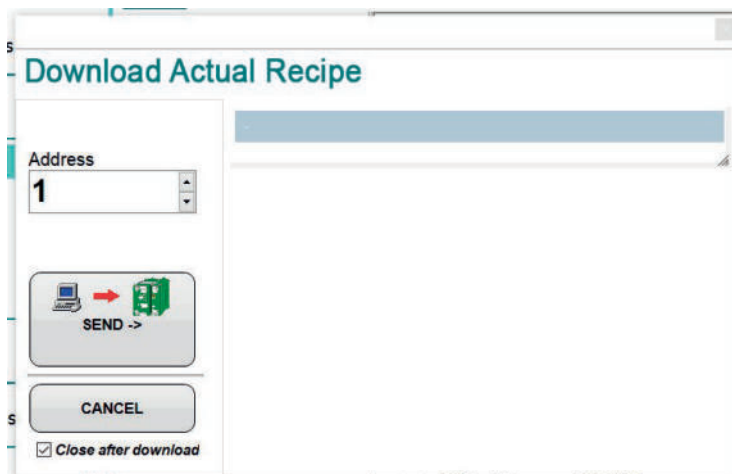

Enter the address of the device to be set in the Address box.
Once the correct address has been set, click on the **"Send"** button to start the Write procedure.

8.3.5. Auto Tuning

Automatic Tuning procedures are used to achieve stable tuning, without having to be an expert on how the PID tuning algorithm works.

Different types of tuning are available depending on requirements:

- Pre Tune
- Self Tune
- Tuning Once

Pre Tune

With the Pre Tune function, the instrument generates an oscillation in order to calculate the inertia and response of the system. Based on the data collected, the instrument calculates the optimal PID parameters for stable control.

NOTE: For greater accuracy in calculating the PID parameters, it is recommended to start the tuning procedure in manual mode, when the process deviates by at least 10% of the full scale.

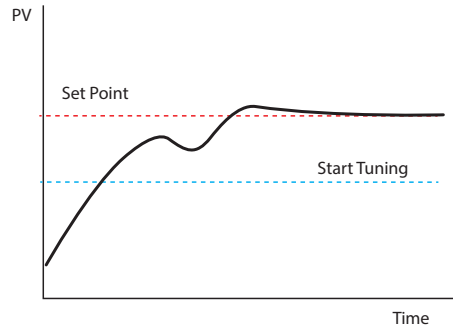

Pre Tune function is enabled for each Loop, with the parameter "Tune" in the PID menu, or via serial by setting '2' on the parameters:

- Loop 1 Tune Add 2085,
- Loop 2 Tune Add 2111,
- Loop 3 Tune Add 2137,

If enabled, the Pre Tune button in the Test section of the configurator will also be enabled.

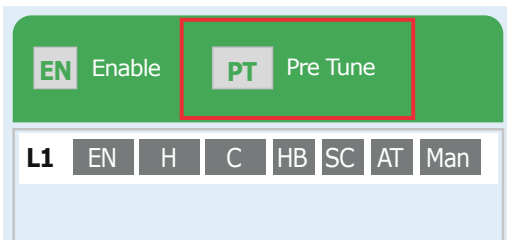

To perform the Pre Tune function, press the **PT Pre Tune** key or via serial write the value '1' on the parameters with modbus address:

- 1216 (for Loop1)
- 1217 (for Loop2)
- 1218 (for Loop3)

Once the function is completed, the parameter will be reset to 0 automatically.

During Pre Tune operation the 'AT' LED on the configurator will be on.

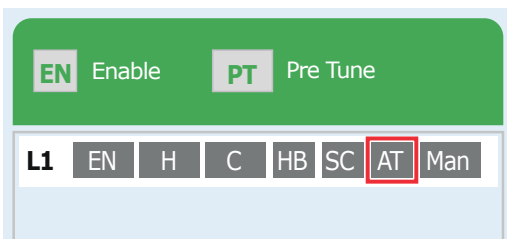

Once activated, to stop tuning manually write '0' on the modbus word of the respective command word.

The starting threshold of the tuning calculation is given by the formula:

$$\text{Tune threshold} = \text{Set Point} - \text{"Set Deviation Tune (P86 Add 2086)"}$$

Example: if the set point is 100.0°C and the parameter P86 is 20.0°C the starting threshold for the calculation of the PID parameters is (100.0 - 20.0) = 80.0°C.

Tuning once

The AutoTune procedure is only executed once the next time the REVO RT is switched on. If for any reason the procedure fails, it will be performed at the next reboot.

The Tune Once function is enabled for each Loop, with the 'Tune' parameter in the configurator for each Loop, or via serial by setting '3' on the parameters:

- Loop 1 Tune Add 2085
- Loop 2 Tune Add 2111
- Loop 3 Tune Add 2137.

Self Tune

The Self Tune function is used to optimise the PID automatically when environmental conditions change.

The Self Tune function is enabled for each Loop with the parameter 'Tune' in the configurator for each Loop, or via serial by setting '1' on the parameters:

- Loop 1 Tune Add 2085
- Loop 2 Tune Add 2111
- Loop 3 Tune Add 2137.

The controller analyses process fluctuations and optimises the PID parameters to achieve a stable process if the control fluctuates outside a threshold set by the parameter in the PID menu:

- Loop 1, SP deviation to activate Self Tune Add 2101
- Loop 2, SP deviation to activate Self Tune Add 2107
- Loop 3, SP deviation to activate Self Tune Add 2153.

When in operation, the values at the Modbus address are as follows:

- 1216 = value 1 for Loop 1
- 1217 = value 1 for Loop 2
- 1218 = value 1 for Loop 3.

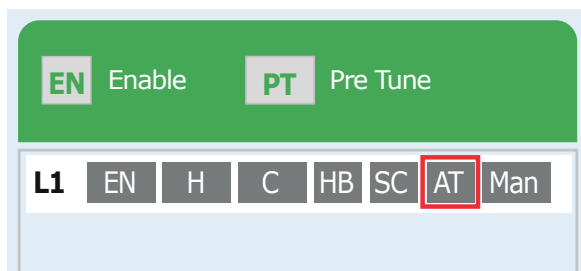
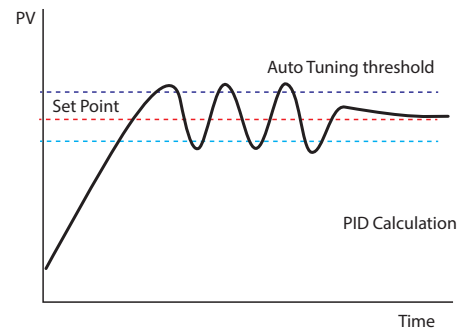

On the configurator software during Pre Tune operation the 'AT' LED will be on.

Manual Tuning

When automatic tuning is not possible, the parameters must be calculated manually.

The manual calculation of parameters must be done experimentally, by oscillating the temperature and observing the reaction of the system, such as temperature and oscillation time.

Calibration with single action zones

With this simplified method, it is possible to find PID parameters with a good compromise between speed of arrival at the SP and limiting overshoot and oscillations.

First set an ON/OFF control by resetting the parameters:

- Proportional band (parameters 2086, 2113, 2139) = 0,
- Integral time (parameters 2087, 2114, 2140) = 0
- Derivative time (parameters 2088, 2115, 2141) = 0.

Attention: Oscillations may exceed the setpoint value, assess whether this over-temperature is acceptable for the equipment.

Starting from the ambient temperature, set the Setpoint and note the fluctuations.

You will get a curve similar to the one in the following image:

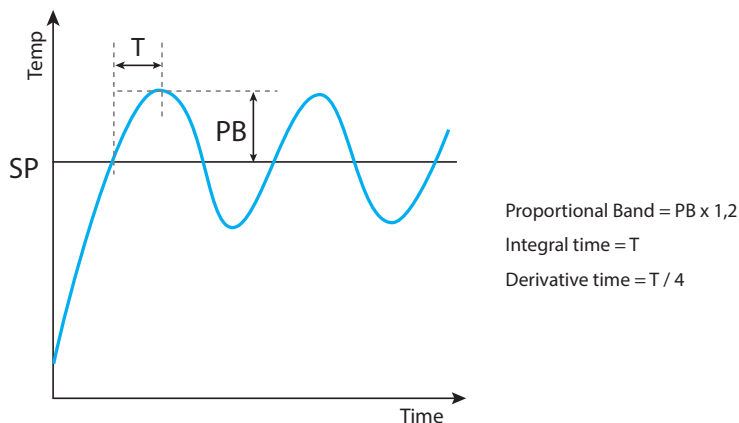

Once the values have been calculated, they must be entered into the parameters:

- Proportional band (parameters 2086, 2113, 2139) = 0,
- Integral time (parameters 2087, 2114, 2140) = 0
- Derivative time (parameters 2088, 2115, 2141) = 0.

8.3.6 Digital Input Functions

Functions can be associated with a digital input by setting the 'DI function' parameter on the test page of the configurator, or via serial with parameter P233 Add 2233.

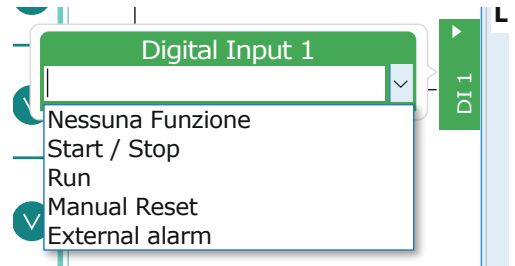

Available functions are:

0 = No function	No associated function.
1 = Start / Stop	Accepts a pulse contact for controller start or stop.
2 = Run	If input is active, regulation is enabled. NOTE: With the controller in STOP mode, the alarms remain active.
3 = Manual Reset	Performs alarm reset if manual reset is set.
4 = External alarm	With the digital input active, the controller goes into STOP and the alarms are deactivated. The controller does not return to START automatically, user intervention is required for this operation.

NOTE: the status of the digital input is always visible on parameter Add 1010 or in the status table on parameter Add 1016 even if "No Function" is assigned.

8.3.7 Automatic/manual output percentage control

The controller output can be controlled manually by setting the output percentage value or by leaving the PID to control this value automatically.

The Automatic/Manual selection is given by the parameters:

- 1219 = value 0: Manual / value 1: Automatic for Loop 1
- 1220 = value 0: Manual / value 1: Automatic for Loop 2
- 1221 = value 0: Manual / value 1: Automatic for Loop 3

or from table Add 1215:

- Bit 0 = Manual / Automatic for Loop 1
- Bit 1 = Manual / Automatic for Loop 2
- Bit 2 = Manual / Automatic for Loop 3

Or from the configurator software by clicking "A/M"

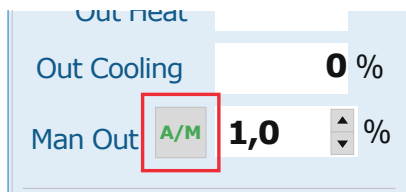

If the setting is Heating only, the value can be set as: $0 \div 100$ / $0.0 \div 100.0$ / $0.00 \div 100.00$
 if the setting is Heating/Cooling, the value can be set as: $-100 \div 100$ / $-100.0 \div 100.0$ / $-100.00 \div 100.00$
 through the parameters:

- 1230, 1229, 1228 for Loop 1
- 1239, 1238, 1237 for Loop 2
- 1248, 1247, 1246 for Loop 3

Or it can be set by the configurator only as: $0.0 \div 100.0$ / $0.00 \div 100.00$

8.3.8 Dual-action operation (Hot-Cold)

REVO RTL can make adjustments involving only Heating (Hot only) or a combined action of Heating and Cooling (Hot/Cold).

The Hot/Cold action is obtained by the following steps:

1. configuring the main command as Heating with the parameter **"ActionType"** = **"Heat"** in the "Heat Output" menu parameters of each loop:
 - DO1 → "Relay 1 Function" Add 2047 = Hot (Value "0")
 - DO1 → "Relay 1 Function" Add 2061 = Hot (Value "0") for Loop 2
 - DO1 → "Relay 1 Function" Add 2075 = Hot (Value "0") for Loop 3
2. by connecting at least one of the 5 Digital Relay Outputs (DO1, DO2,...DO5), to the cooling function via the parameters:
 - DO1 → "Relay 1 Function" Add 2219
 - DO2 → "Relay 2 Function" Add 2021
 - DO3 → "Relay 3 Function" Add 2223
 - DO4 → "Relay 4 Function" Add 2025
 - DO5 → "Relay 5 Function" Add 2027
3. raising the configuration bits on each output
 - Bit 0 = "Cooling" Loop 1
 - Bit 1 = "Cooling" Loop 2
 - Bit 2 = "Cooling" Loop 3



The PID control uses the parameters in the PID menu to adjust each loop, like this:

- | | | |
|-----------------------------------|---|---|
| "Proportional Band" parameter | → | Proportional band <i>Heating action</i> |
| "Integral time" parameter | → | Integral time <i>Heating action</i> and <i>Cooling action</i> |
| "Derivative Time" parameter | → | Derivative time <i>Heating action</i> and <i>Cooling action</i> |
| "Cooling PB Multiplier" parameter | → | Proportional band <i>Cooling action</i> |
| "Cycle Time Heat" parameter | → | Cycle time <i>Heating action</i> |
| "Cooling Cycle Time" parameter | → | Cycle time <i>Cooling action</i> |

Consequently, the **Proportional Band Cooling action** is given by the operation: **"proportional band"** x **"PB Multiplier Cold"**, while **integral time** and **derivative time** are the same for both actions.

The two bands can be overlapped or spaced with the **"Overlap/Dead Band"** parameter: parameter 2097, 2123, 2149, P149.

For systems in which the heating output and the cooling output must never be active at the same time, the **"Overlap/Dead Band"** parameter is configured by setting a value <0, conversely, if an overlap of the 2 bands is required, this can be configured by setting the **"Overlap/Dead Band"** parameter to a value >0.

8.3.9 Soft-Start function

To safeguard the life of heating elements requiring preheating, the REVO RTL has a Soft-Start function, available in 2 modes:

- Gradient
- Percentage

Both modes preheat, preventing potentially damaging thermal shocks to the heating elements. During activation of the Soft-Start function, parameter 1216 is set to value "5".

Gradient:

When the controller is switched on or enabled via digital input or serial command, the Set Point is reached by following the gradient set on the "Gradient Soft-Start" parameter:

- P241 Add 2241 = value expressed in Units/hour (°C/h) for Loop 1
- P251 Add 2251 = value expressed in Units/hour (°C/h) for Loop 2
- P261 Add 2261 = value expressed in Units/hour (°C/h) for Loop 3

until the temperature set in the 'Soft-Start Threshold' parameter is reached

- P243 Add 2243 = Set Point Soft-Start for Loop 1
- P253 Add 2253 = Set Point Soft-Start for Loop 2
- P263 Add 2263 = Set Point Soft-Start for Loop 3

or after expiry of the time set in the "Soft-Start Time" parameter.

- P244 Add 2244 = Soft-Start time (hh.mm) for Loop 1
- P254 Add 2254 = Soft-Start time (hh.mm) for Loop 2
- P264 Add 2264 = Soft-Start time (hh.mm) for Loop 3.

Percentage:

When the controller is switched on or enabled, the output switches to the power set in parameter "Soft-Start Percentage":

- P242 Add 2242 = Soft-Start exit percentage (0÷100%) for Loop 1
- P252 Add 2252 = Soft-Start exit percentage (0÷100%) for Loop 2
- P262 Add 2262 = Soft-Start exit percentage (0÷100%) for Loop 3

until the temperature set in the 'Soft-Start Threshold' parameter is reached:

- P243 Add 2243 = Set Point Soft-Start for Loop 1
- P253 Add 2253 = Set Point Soft-Start for Loop 2
- P263 Add 2263 = Set Point Soft-Start for Loop 3

or after expiry of the time set in the "Soft-Start Time" parameter:

- P244 Add 2244 = Tempo Soft-Start (hh.mm) for Loop 1
- P254 Add 2254 = Tempo Soft-Start (hh.mm) for Loop 2
- P264 Add 2264 = Tempo Soft-Start (hh.mm) for Loop 3

NOTE: Automatic and manual tuning cannot be enabled if the Soft-Start function is active.

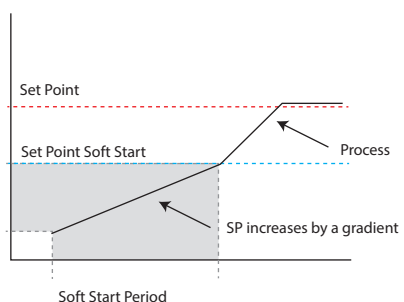
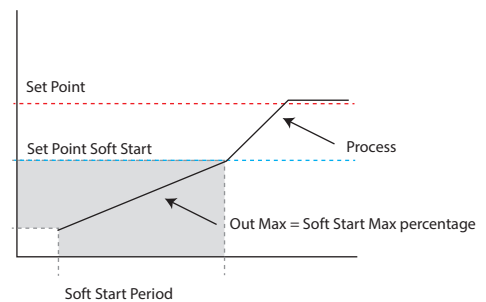

8.3.10 ECO MODE

In order to limit the overlap of the switching on of the 3 zones, the ECO function has been introduced. The ECO function delays the switching on of the second output compared to the first, and of the third output compared to the second, but always remaining within the operating cycle time. In this way, if during temperature control the power of the 3 zones does not exceed 33% utilisation, when the ECO function is activated, shifting the firing avoids overlapping of the three firing, limiting current peaks. If, on the other hand, the 33% threshold is exceeded, the power demand is added to the next zone, but in a much less onerous manner. By avoiding overlaps, consumption is optimized.

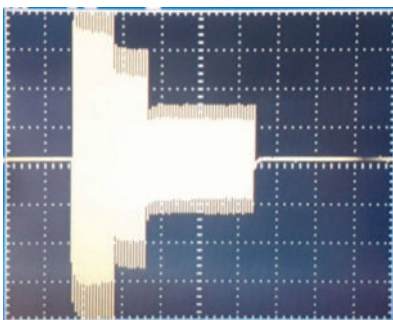
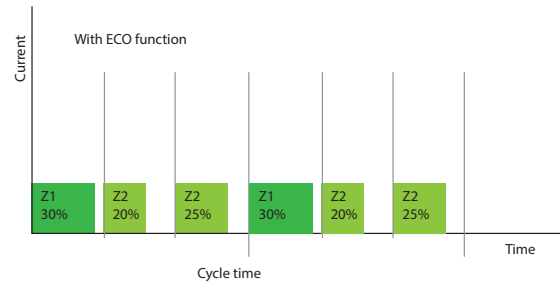
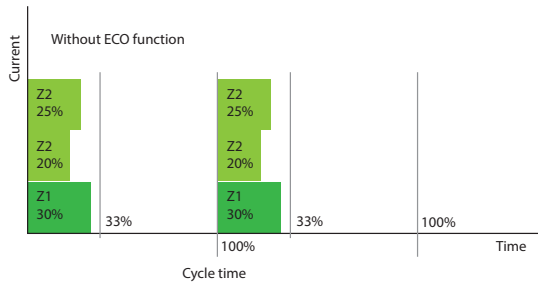

Example of 3 zones in modulation at different control rates, you can see that the signals add up.

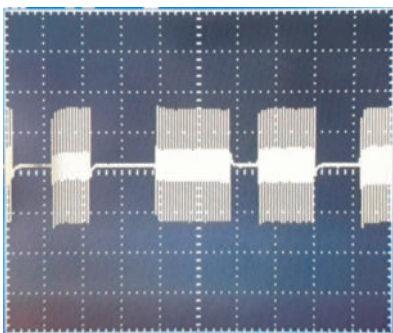

By activating the ECO function, the ignitions are distributed over the available cycle time avoiding overlaps and therefore current peaks.

See parameter P53 in "Configuration parameter list" chapter.

8.3.11 Digital Output (DO) functions

The digital relay outputs are multifunctional outputs; they can be associated with the functions of:

- **Cooling for Loop 1,2 and 3**
With dual action operation, enabling this option associates the cooling control of the corresponding control loop.
- **Alarms 1,2,3,4**
Enabling this option associates the temperature alarm status to this output.
If more alarms are enabled the output will be the logical "OR" operation of the enabled alarms.
And if you enable Alarm 1 and Alarm 2, if one of the 2 alarms activates it will also activate the output.
- **Heater Break**
Enabling this option associates the status of the interrupted load alarm with this output.
If the current falls below the set threshold it will trigger the alarm and the configured output.
- **Watch Dog on RS485**
Enabling this option if there is no traffic on the serial port for more than the set time will trigger the alarm and the configured output.
- **Error on an input**
Enabling this option if one of the three inputs fails (e.g. thermocouple interrupted) will trigger the alarm and the configured output.
- **Replication of DI status**
By enabling this option, the configured output represents the status of the digital input.
- **RUN status for Loop 1,2 and 3**
Enabling this option associates the status of enabling one or more control loops to the configured output.
If multiple Loops are enabled, the output will be the logical "OR" operation of the enabled alarms.
And if you enable 'RUN Loop 1' and 'RUN Loop 2', if one of the 2 is enabled it will also enable the output.
- **Remote command 1 and 2**
Enabling this option associates the status of 2 serial commands with the configured output.

The various functions can also be combined to have several functions on one output.
See parameters P219, P221, P223, P225, P227 in "Configuration parameter list" chapter.
E.g.: It is possible to associate on one output the status of 2 alarms + the status of the sensors + the status of the Heater Break

▼ Uscite Relè			
▼ DO1			
▼ 2219	P219	Funzione Relè 1	Enabled
		0- Cool Loop 1	- Disabled -
		1- Cool Loop 2	- Disabled -
		2- Cool Loop 3	- Disabled -
		3- allarme 1	- Disabled -
		4- allarme 2	- Disabled -
		5- allarme 3	- Disabled -
		6- allarme 4	- Disabled -
		7- H.B.	- Disabled -
		8- RS485 Watch Dog	- Disabled -
		9- Probe error	- Disabled -
		10- Digital input	- Disabled -
		11- Run Loop 1	- Disabled -
		12- Run Loop 2	- Disabled -
		13- Run Loop 3	- Disabled -
		14- Remoto 1	- Disabled -
		15- Remoto 2	- Disabled -
2220	P220	Tipo Relè 1	N.O.

8.3.12 Load diagnostics function (HB)

The load diagnostic function Heater Break (HB) reads the current and checks it against a threshold. If the current goes below the threshold, the controller signals an alarm, which can be associated with a digital output.

To read the correct current value, set the mains frequency (CTx Function) and the CT/TA current transformer size (Size).

The threshold is a percentage (HB Sens %) relative to the load current (Load. Nom Curr.).

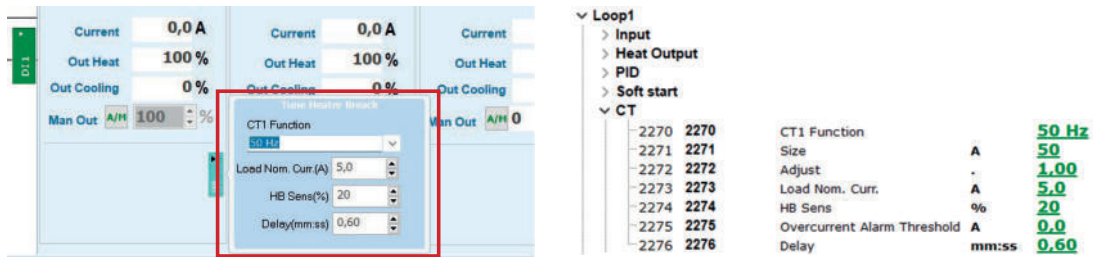

The current transformer (CT) can have different sizes with the following dimensions:

Description	Size	Code
Current transformer 38x48x20mm 25/0.05A	25/0.05A	CT25
Current transformer 38x48x20mm 50/0.05A	50/0.05A	CT50
Current transformer 38x48x20mm 100/0.05A	100/0.05A	CT100
Current transformer 50x50x30mm 100/0.05A	100/0.05A	CTB100
Current transformer 50x50x30mm 150/0.05A	150/0.05A	CTB150
Current transformer 50x50x30mm 200/0.05A	200/0.05A	CTB200

Dimensions:

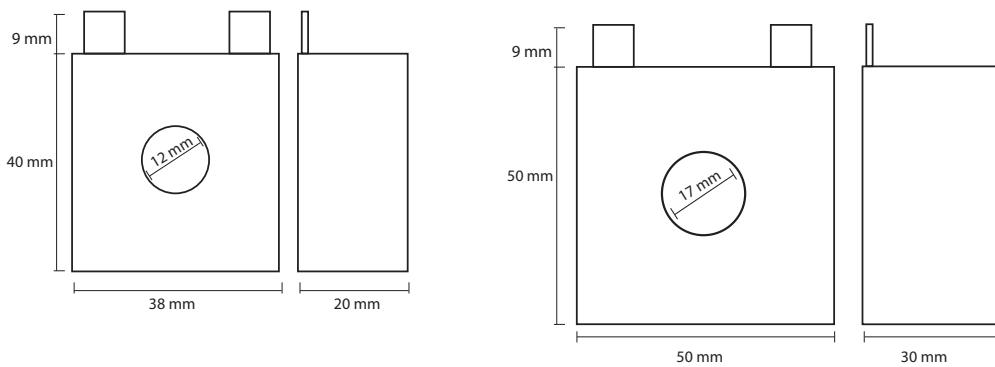

8.3.13 Customisable reading area

There is a 30-parameter area, where it is possible to configure the sequence of parameters to be read. By configuring this area, it is possible to put the most frequently read information in order, facilitating reading by a communication master and using a single multiple read command.

Parameter	Description	R/W
2501	Parameter number to be displayed in parameter Add 1401	R/W
2502	Parameter number to be displayed in parameter Add 1402	R/W
...
...
2530	Parameter number to be displayed in parameter Add 1430	R/W
2531	Parameter number to be displayed in parameter Add 1431	R/W

The values will be read in the parameters

Parameter	Description	R/W
1401	Parameter Value contained in the parameter Add 2501	R
1402	Parameter Value contained in the parameter Add 2502	R
...
...
1430	Parameter Value contained in the parameter Add 2530	R
1431	Parameter Value contained in the parameter Add 2531	R

9 Configuration parameter list

































































9.1 Analog Input

If the thermocouple is subjected to corrosive or abrasive agents, it must be equipped with appropriate protection.

The thermocouple must be positioned so as to have a reliable and stable reading.

Caution: If the sensor is placed inside pipes or far from the point to be controlled, control may be unresponsive and difficult to maintain stable. For a correct reading of the sensor, the wire must be of a compensated type appropriate for the type of thermocouple.

The wire can be distinguished by the colour of the wire and sheath, which however varies from country to country, as shown in the following table:

Thermocouple type	 ANSI MC 96.1	 International IEC 584-3	 International IEC 584-3 Sinc. intrinsic	 BS 1843	 DIN 43710	 JIS C1610-1981	 NFE-18001	Notes on the use of conductor material
J Fe Cu-Ni								Reducing, Vacuum, Inert Limited use in high temperature oxidising environment Not recommended for high temperatures
K Ni-Cr Ni-Al								Oxidising and inert Limited use in the presence of a vacuum reducing atmosphere Wide temperature range Wide calibration
T Cu Cu-Ni								Slightly oxidising Reducing atmosphere, Vacuum or Inert Good behaviour in the presence of moisture - Low temperature and cryogenic application
E Ni-Cr Cu-Ni								Oxidising or Inert Limited use in reducing or vacuum environment Has the highest EMF value per grade
N Ni-Cr-Si Ni-Si-Mg								Alternative to Type K More stable at high temperatures
R Pt 13% Rh Pt								Oxidising or inert - Do not insert into metal pipes Beware of danger of contamination
S Pt 10% Rh Pt								High temperatures
U Cu Cu-Ni								TC Extension Cable Type R and S Also known as RX and SX
B Pt 30% Rh Pt 6% Rh								Oxidising or inert - Do not insert into metal pipes Beware of danger of contamination - High temperatures Widespread use in the glass industry

P1 – Input type Loop 1 (ModBus Address 2001)

P15 - Input type Loop 2 (ModBus Address 2015)

P29 - Input type Loop 3 (ModBus Address 2029)

Analogue input configuration / sensor AI1 selection

- 1 Tc-K -260° C ÷ 1360° C (Default)
- 2 Tc-S -40° C ÷ 1760° C
- 3 Tc-R -40° C ÷ 1760° C
- 4 Tc-J -200° C ÷ 1200° C
- 5 Tc-T -260° C ÷ 400° C
- 6 Tc-E -260° C ÷ 980° C
- 7 Tc-N -260° C ÷ 1280° C
- 8 Tc-B 100° C ÷ 1820° C
- 9 0-1 0 ÷ 1 V
- 10 0-5 0 ÷ 5 V
- 11 0-10 0 ÷ 10 V
- 12 0-20 0 ÷ 20 mA
- 13 4-20 4 ÷ 20 mA
- 14 0-60 0 ÷ 60 mV

P2 - Lower limit Loop 1 (ModBus Address 2002)
P16 - Lower limit Loop 2 (ModBus Address 2016)
P30 - Lower limit Loop 3 (ModBus Address 2030)

Lower limit of analogue input

E.g.: with 4 ÷ 20 mA input this parameter takes on the value associated with 4 mA.

-32767 ÷ +32767 [digit]

Default: 0

P3 - Upper limit Loop 1 (ModBus Address 2003)
P17 - Upper limit Loop 2 (ModBus Address 2017)
P31 - Upper limit Loop 3 (ModBus Address 2031)

Upper limit of analogue input

E.g.: with 4 ÷ 20 mA input this parameter takes on the value associated with 20 mA.

-32767 ÷ +32767 [digit]

Default: 1000

P4 - Over limits Loop 1 (ModBus Address 2004)
P18 - Over limits Loop 2 (ModBus Address 2018)
P32 - Over limits Loop 3 (ModBus Address 2032)

If set as linear input, it allows the process to exceed the limits (Par. P2 and P3)

- 0 Disabled (**Default**)
- 1 Enabled

P5 - Offset input Loop 1 (ModBus Address 2005)
P19 - Offset input Loop 2 (ModBus Address 2019)
P33 - Offset input Loop 3 (ModBus Address 2033)

Value in algebraic sum to the displayed process

-10000 ÷ +10000 [digit] (degrees.tenths for temperature sensors).

Default: 0

P6 - Multiplier Loop 1 (ModBus Address 2006)
P20 - Multiplier Loop 2 (ModBus Address 2020)
P34 - Multiplier Loop 3 (ModBus Address 2034)

Displayed process multiplier value expressed as a percentage of full scale

E.g.: To correct a display with a scale of 0 to 1000°C displaying 0 to 1010°C, set the parameter to -1.0%.

$1000 * (-1\%) = -10 \rightarrow 1010 + 10 = 1000$

$-1000 (-100.0\%) \div 1000 (+100.0\%),$

Default: 0.0%.

P7 - Loop 1 Filter (Address ModBus 2007)
P21 - Loop 2 Filter (Address ModBus 2021)
P35 - Loop 3 Filter (Address ModBus 2035)

Filter used to increase reading stability

Increasing the value slows down the speed of the control loop

1 ÷ 15.

Default: 10

P8 - Units of measurement for all Loops (ModBus Address 2008)

- 0 °C - Degrees Celsius (**Default**)
- 1 °F - Degrees Fahrenheit
- 2 K - Kelvin

P9 - Conversion frequency for all loops (ModBus Address 2009)

Input sampling rate.

Increasing the conversion speed decreases the reading stability

(E.g.: for fast variables such as pressure, it is advisable to increase the sampling rate).

- 0 4.17 Hz (Minimum conversion speed)
- 1 6.25 Hz
- 2 8.33 Hz
- 3 10.0 Hz
- 4 12.5 Hz
- 5 16.7 Hz (Default) Ideal for filtering noise 50/60 Hz
- 6 19.6 Hz
- 7 33.2 Hz
- 8 39.0 Hz
- 9 50.0 Hz
- 10 62.0 Hz
- 11 123 Hz
- 12 242 Hz
- 13 470 Hz (Maximum conversion speed)

P14 - Decimal point Loop 1 (ModBus Address 2014)**P28 - Decimal point Loop 2 (ModBus Address 2028)****P42 - Decimal point Loop 3 (ModBus Address 2042)**

Number of decimals; read-only value. Value depends on input type selected

9.2 SSR control outputs

P43 - Command Output Loop 1 (ModBus Address 2043)

Enables control output 1 related to Loop 1

- 0 Disabled Output disabled
- 1 Enabled Output enabled (**Default**)
- 2 3.PHA Output enabled in three-phase mode (Loop 2 and Loop 3 will no longer be active, while the three SSRs will be switched on in parallel with output 1)

P57 - Command Output Loop 2 (ModBus Address 2057)

P71 - Command Output Loop 3 (ModBus Address 2071)

Enables control outputs 2 and 3 related to Loop 2 and 3

- 0 Disabled Output disabled
- 1 Enabled Output enabled (**Default**)

P44 - Initial state Loop 1 (ModBus Address 2044)

P58 - Initial state Loop 2 (ModBus Address 2058)

P72 - Initial state Loop 3 (ModBus Address 2072)

Selects the initial state of control zone 1 after switch-on

- 0 Start Enabled zone (**Default**)
- 1 Stop Disabled zone
- 2 Last state Start/Stop status before shutdown

P45 - Input select Loop 1 (ModBus Address 2045)

P59 - Input select Loop 2 (ModBus Address 2059)

P73 - Input select Loop 3 (ModBus Address 2073)

Selects the input connected to the control loop

- 0 Input 1 (**Default**)
- 1 Input 2
- 2 Input 3

P46 - Connected setpoint Loop 1 (ModBus Address 2046)

P60 - Connected setpoint Loop 2 (ModBus Address 2060)

P74 - Connected setpoint Loop 3 (ModBus Address 2074)

Selects the reference setpoint at the control loop

- 0 Setpoint 1 (**Default**)
- 1 Setpoint 2
- 2 Setpoint 3

P47 - Type of control action Loop 1 (ModBus Address 2047)

P61 - Type of control action Loop 2 (ModBus Address 2061)

P75 - Type of control action Loop 3 (ModBus Address 2075)

Action type for control loop output

- 0 Hot Reverse action (**Default**)
- 1 Cold Direct action

P48 - Hysteresis Loop 1 (ModBus Address 2048)
P62 - Hysteresis Loop 2 (ModBus Address 2062)
P76 - Hysteresis Loop 3 (ModBus Address 2076)

Hysteresis value for control, when process control is ON/OFF

-10000 ÷ +10000 [digit] with analog input

-1000.0 ÷ +1000.0° with thermocouple

Default: 0.2.

P49 - Percentage of output with error input Loop 1 (ModBus Address 2049)
P63 - Percentage of output with error input Loop 2 (ModBus Address 2063)
P77 - Percentage of output with error input Loop 3 (ModBus Address 2077)

Fixed output percentage in the event of an input sensor error

If configured in Hot/Cold the negative value indicates the percentage of the cold output

-100% ÷ +100% Command output percentage.

Default: 0%.

P50 - Type of error control on the input Loop 1 (ModBus Address 2050)
P64 - Type of error control on the input Loop 2 (ModBus Address 2064)
P78 - Type of error control on the input Loop 3 (ModBus Address 2078)

Selects the operating mode of the error control function

When active it forces the output to the value contained in parameter 49

- 0 Error generated by loop 1 probe break (**Default**)
- 1 Error generated by breakage of any probe

P51 - Percentage output when in Stop Loop 1 (ModBus Address 2051)
P65 - Percentage output when in Stop Loop 2 (ModBus Address 2065)
P79 - Percentage output when in Stop Loop 3 (ModBus Address 2079)

Fixed percentage of control output with controller in STOP mode

If configured in Hot/Cold the negative value indicates the percentage of the cold output

-100% ÷ +100% Command output percentage.

Default: 0%.

P52 - Enabling memorisation Manual status Loop 1 (ModBus Address 2052)
P66 - Enabling memorisation Manual status Loop 2 (ModBus Address 2066)
P80 - Enabling memorisation Manual status Loop 3 (ModBus Address 2080)

If enabled, at switch-on the controller returns to the automatic or manual mode prior to switch-off, also retaining any output percentage.

If in automatic operation, in the event of a probe rupture, the controller will switch to manual, maintaining the value of the output percentage generated by the PID just before the rupture.

- 0 Disabled (**Default**)
- 1 Enabled

P53 - Enabling Eco Mode  function for each Loop (Address ModBus 2053)

Function can only be enabled in single-phase mode (see Par P43)

It manages the active zones using the cycle time of loop 1 at all times, staggering the activation of loop 2 and 3 outputs by 1/3 of the cycle time. By doing so, as long as the output percentage remains below 33.3% the outputs will not overlap.

- 0 Disabled (**Default**)
- 1 Enabled

9.3 Autotuning and PID

P85 - Tune Loop 1 (ModBus Address 2085)

P111 - Tune Loop 2 (ModBus Address 2111)

P137 - Tune Loop 3 (ModBus Address 2137)

Type of Active Tuning

- 0 Disabled **(Default)**
- 1 Self Tune PID with continuous parameter calculation
- 2 Pre Tune PID with parameter calculation on command
- 3 Pre Tune PID with one-time parameter calculation on restart
Once

P86 - Setpoint deviation for Pretune activation Loop 1 (ModBus Address 2086)

P112 - Setpoint deviation for Pretune activation Loop 2 (ModBus Address 2112)

P138 - Setpoint deviation for Pretune activation Loop 3 (ModBus Address 2138)

Threshold for starting the oscillation required to calculate PID parameters with the Pretune function

0-10000 [digit]

0.0-1000.0° with thermocouple.

Default: 30.0.

P87 - Proportional band Loop 1 (ModBus Address 2087)

P113 - Proportional band Loop 2 (ModBus Address 2113)

P139 - Proportional band Loop 3 (ModBus Address 2139)

Proportional band for PID process control (process inertia)

If Proportional Band = 0 and Integral Time = 0, the regulation becomes ON / OFF

1 ÷ 10000 [digit]

0.1 ÷ 1000.0° with thermocouple.

Default: 0

P88 - Integral time Loop 1 (ModBus Address 2088)

P114 - Integral time Loop 2 (ModBus Address 2114)

P140 - Integral time Loop 3 (ModBus Address 2140)

Integral time for PID process control (duration of process inertia)

0.0 ÷ 2000.0 seconds (0.0 = integral disabled),

Default: 0.0

P89 - Derivative time Loop 1 (ModBus Address 2089)

P115 - Derivative time Loop 2 (ModBus Address 2115)

P141 - Derivative time Loop 3 (ModBus Address 2141)

Derivative time for PID process control (usually ¼ of integral time)

0.0 ÷ 1000.0 seconds (0.0 = derivative disabled),

Default: 0

P90 - Inactivity band Loop 1 (ModBus Address 2090)
P116 - Inactivity band Loop 2 (ModBus Address 2116)
P142 - Inactivity band Loop 3 (ModBus Address 2142)

Band around the SP within which the output percentage does not vary

Function mainly used when controlling valves to avoid continuous variations not useful for regulation

0 ÷ 10000 [digit]

0.0 ÷ 1000.0 ° with thermocouple.

Default: 0

P91 - Proportional band centred Loop 1 (ModBus Address 2091)
P117 - Proportional band centred Loop 2 (ModBus Address 2117)
P143 - Proportional band centred Loop 3 (ModBus Address 2143)

Defines whether the proportional band should be centred on the setpoint

In double-loop operation (hot/cold) it is always disabled (not centred)

- 0 Disabled Band below (hot) or above (cold) (**Default**)
- 1 Enabled Centred band

P92 - Auto switch-off above a threshold Loop 1 (ModBus Address 2092)
P118 - Auto switch-off above a threshold Loop 2 (ModBus Address 2118)
P144 - Auto switch-off above a threshold Loop 3 (ModBus Address 2144)

In PID operation, it enables the control output of the SCR to be switched off when a certain threshold is exceeded. (setpoint + P93)

- 0 Disabled (**Default**)
- 1 Enabled

P93 - Threshold for auto switch-off above a threshold Loop 1 (ModBus Address 2093)
P119 - Threshold for auto switch-off above a threshold Loop 2 (ModBus Address 2119)
P145 - Threshold for auto switch-off above a threshold Loop 2 (ModBus Address 2145)

Set the deviation from the setpoint, for calculating the intervention threshold for the 'Auto-Off' function above the threshold

-10000 ÷ +10000 [digit]

-1000.0 ÷ 1000.0° with thermocouple.

Default: 0

P94 - Cycle time Loop 1 (ModBus Address 2094)
P120 - Cycle time Loop 2 (ModBus Address 2120)
P146 - Cycle time Loop 3 (ModBus Address 2146)

Cycle time used in modulation with PID control

When connected to a contactor the value is generally between 15 and 30s.

When connected to a SSR with SSR input, the value is generally between 1 and 2s.

1-300 seconds

Default: 2 seconds

P95 - Cooling type Loop 1 (ModBus Address 2095)
P121 - Cooling type Loop 2 (ModBus Address 2121)
P147 - Cooling type Loop 3 (ModBus Address 2147)

The type of cooling used for control in hot/cold PID mode is defined
 NOTE: Enable cold output in parameter "Relais function DOx".

- 0 Air (**Default**)
- 1 Oil
- 2 Water

P96 - Cold proportional band multiplier Loop 1 (ModBus Address 2096)
P122 - Cold proportional band multiplier Loop 2 (ModBus Address 2122)
P148 - Cold proportional band multiplier Loop 3 (ModBus Address 2148)

When the process is configured as hot/cold PID, the proportional band for the cold action is given by the value of the parameter "Proportional band 1" multiplied by this value.

1.00 ÷ 5.00
Default: 1.00

P97 - Overlap / Dead Band Loop 1 (ModBus Address 2097)
P123 - Overlap / Dead Band Loop 2 (ModBus Address 2123)
P149 - Overlap / Dead Band Loop 3 (ModBus Address 2149)

When the process is configured as hot/cold PID, the Overlap/Dead Band function defines whether the heating action and the cooling action can overlap or must have a dead band between the two actions.

-20.0% ÷ 50.0%
 Negative: Dead Band
 Positive: Overlap
Default: 0.0%

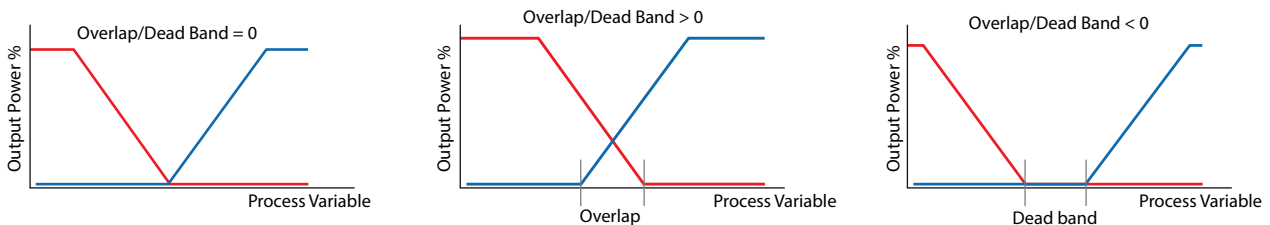

P98 - Cooling cycle time Loop 1 (ModBus Address 2098)
P124 - Cooling cycle time Loop 2 (ModBus Address 2124)
P150 - Cooling cycle time Loop 3 (ModBus Address 2150)

Cycle time for cold output when set in hot/cold PID mode

1 ÷ 300 seconds
Default: 10 seconds

P99 - Low output percentage limit Loop 1 (ModBus Address 2099)
P125 - Low output percentage limit Loop 2 (ModBus Address 2125)
P151 - Low output percentage limit Loop 3 (ModBus Address 2151)

Minimum value of power output percentage

0% ÷ 100%
Default: 0%

P100 - Maximum output percentage limit Loop 1 (ModBus Address 2100)
P126 - Maximum output percentage limit Loop 2 (ModBus Address 2126)
P152 - Maximum output percentage limit Loop 3 (ModBus Address 2152)

Maximum value of power output percentage

0% ÷ 100%

Default: 100%

P101 - Maximum deviation for SelfTune activation Loop 1 (ModBus Address 2101)
P127 - Maximum deviation for SelfTune activation Loop 2 (ModBus Address 2127)
P153 - Maximum deviation for SelfTune activation Loop 3 (ModBus Address 2153)

When the automatic PID calculation is active (Self Tune), this parameter sets the maximum process-setpoint deviation beyond which the automatic tune recalculates the PID parameters

8 ÷ 10000 [digit]

0,8 ÷ 1000,0° with thermocouples.

Default: 2.0

P102 - Minimum proportional band Loop 1 (ModBus Address 2102)
P128 - Minimum proportional band Loop 2 (ModBus Address 2128)
P154 - Minimum proportional band Loop 3 (ModBus Address 2154)

Minimum proportional band value for automatic PID calculation (Pretune)

0 ÷ 10000 [digit]

0,0 ÷ 1000,0° with thermocouples.

Default: 3.0

P103 - Maximum proportional band Loop 1 (ModBus Address 2103)
P129 - Maximum proportional band Loop 2 (ModBus Address 2129)
P155 - Maximum proportional band Loop 3 (ModBus Address 2155)

Maximum proportional band value for automatic PID calculation (Pretune)

0 ÷ 10000 [digit]

0,0 ÷ 1000,0° with thermocouples.

Default: 100.0

P104 - Minimum integral time Loop 1 (Address ModBus 2104)
P130 - Minimum integral time Loop 2 (Address ModBus 2129)
P156 - Minimum integral time Loop 3 (Address ModBus 2156)

Minimum integral time value for automatic PID calculation (Pretune)

0.0 ÷ 1000.0 seconds

Default: 30.0 seconds

P105 - Overshoot function level Loop 1 (ModBus Address 2105)
P131 - Overshoot function level Loop 2 (ModBus Address 2131)
P157 - Overshoot function level Loop 3 (ModBus Address 2157)

The overshoot function level prevents this when the setpoint is reached or when the setpoint is changed. Setting too low a value may result in the overshoot not being fully absorbed, while too high values may result in the process reaching the setpoint more slowly.

0 Disabled

1 ÷ 10 [Lev.1 ÷ Lev.10]

Default: Lev.5

9.4 Alarms

P163 - Alarm function 1 (ModBus Address 2163)

P177 - Alarm function 2 (ModBus Address 2177)

P191 - Alarm function 3 (ModBus Address 2191)

P177 - Alarm function 4 (ModBus Address 2177)

NOTE: Alarm 4 is the AND condition of the 3 zones with the configured alarm

E.g.: If I configure Alarm 4 Absolute Low, if all three variables are lower than the Alarm 4 threshold, then it signals the alarm

Assuming that:

PV = Process Variable

SP = Regulation SetPoint

AL = Alarm threshold

AL_L = Low Alarm Threshold for Asymmetrical Alarm

AL_H = High Alarm Threshold for Asymmetrical Alarm

Select Alarm 1 type.

- 0 Disabled (**Default**)
- 1 Absolute of high. Absolute referred to PV, active when PV exceeds threshold
- 2 Absolute of low. Absolute referred to PV, active when PV below threshold
- 3 Band alarm (SP ± alarm setpoint)
- 4 Asymmetric band alarm (SP + AL_H e SP - AL_L)
- 5 High deviation. Deviation alarm, active when PV exceeds SP + AL
- 6 Low deviation. Deviation alarm, active when PV goes below SP - AL
- 7 Absolute on high of SP. Absolute referred to SP, active when SP above threshold
- 8 Absolute on low of SP. Absolute referred to SP, active when SP below threshold

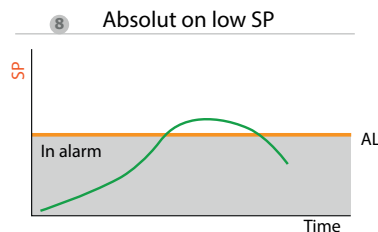
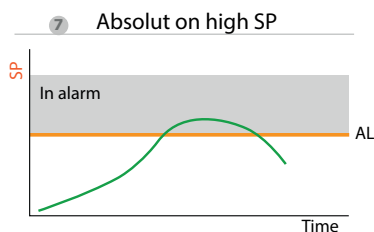
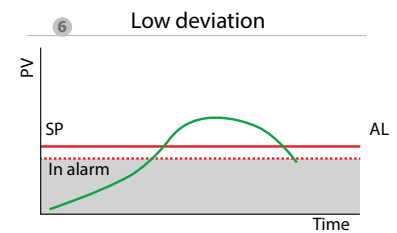
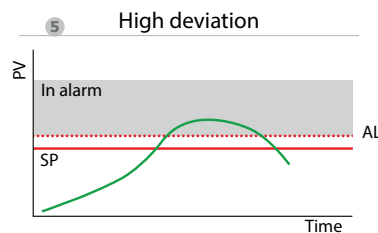
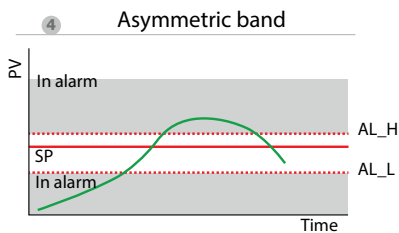
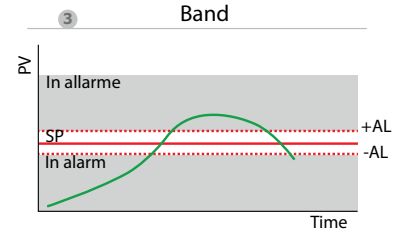
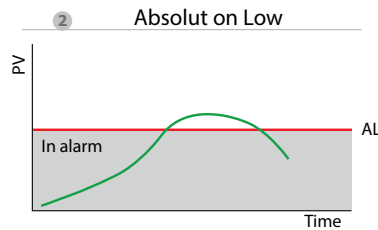
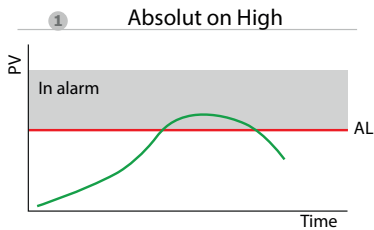

P164 - Input selection Alarm 1 (ModBus Address 2164)
P178 - Input selection Alarm 2 (ModBus Address 2178)
P192 - Input selection Alarm 3 (ModBus Address 2192)

Selects the input connected to the alarm

- 0 Input 1. (**Default** for Alarm1)
- 1 Input 2. (**Default** for Alarm2)
- 2 Input 3. (**Default** for Alarm3)

Alarm 4, Alarm 5 not available

P165 - Reference SP selection for Alarm 1 (ModBus Address 2165)
P179 - Reference SP selection for Alarm 2 (ModBus Address 2179)
P193 - Reference SP selection for Alarm 3 (ModBus Address 2193)

Select Reference Loop

- 0 SP 1. (**Default** for Alarm1)
- 1 SP 2. (**Default** for Alarm2)
- 2 SP 3. (**Default** for Alarm3)

Alarm 4 not available

P166 - Alarm 1 State Output (ModBus Address 2166)
P180 - Alarm 2 State Output (ModBus Address 2180)
P194 - Alarm 3 State Output (ModBus Address 2194)
P208 - Alarm 4 State Output (ModBus Address 2208)

Contact type alarm output 1 and trip type

- 0 (N.O. Start) Normally open, active from Start (**Default**)
- 1 (N.C. Start) Normally closed, active from Start
- 2 (N.O. Threshold) operational when the alarm is reached
- 3 (N.C. Threshold) operational when the alarm is reached
- 4 (N.O. Threshold Variation) inhibited after command set change
- 5 (N.C. Threshold Variation) inhibited after command set change

P167 - Hysteresis Alarm 1 (ModBus Address 2167)
P181 - Hysteresis Alarm 2 (ModBus Address 2181)
P195 - Hysteresis Alarm 2 (ModBus Address 2195)
P209 - Hysteresis Alarm 4 (ModBus Address 2209)

Alarm hysteresis

-10000 ÷ +10000 [digit] (degrees.tenths for temperature sensors).

Default: 0.5.

P168 - Reset Alarm 1 (ModBus Address 2168)
P182 - Reset Alarm 2 (ModBus Address 2182)
P196 - Reset Alarm 3 (ModBus Address 2196)
P210 - Reset Alarm 4 (ModBus Address 2210)

Alarm contact reset type

- 0 Automatic reset (**Default**)
- 1 Manual reset (manual reset from keypad or digital input)
- 2 Manual reset stored (maintains the output status even after a power failure)
- 3 Automatic reset with time activation. The alarm remains active for the time set in the 'Alarm Delay' parameter P171, P185, P199, P213, even if the conditions that generated it cease to exist. The alarm conditions must be cancelled in order to be able to intervene again.

P169 - Alarm 1 State Error (ModBus Address 2169)
P183 - Alarm 2 State Error (ModBus Address 2183)
P197 - Alarm 3 State Error (ModBus Address 2197)
P211 - Alarm 4 State Error (ModBus Address 2211)

Status of alarm output in the event of an error

- 0 Open contact (**Default**)
- 1 Closed contact

P170 - Alarm 1 State Stop (ModBus Address 2170)
P184 - Alarm 2 State Stop (ModBus Address 2184)
P198 - Alarm 3 State Stop (ModBus Address 2198)
P212 - Alarm 4 State Stop (ModBus Address 2212)

Alarm output status with controller in STOP

- 0 open Open contact (**Default**)
- 1 close Closed contact

P171 - Alarm 1 Delay (ModBus Address 2171)
P185 - Alarm 2 Delay (ModBus Address 2185)
P199 - Alarm 3 Delay (ModBus Address 2199)
P213 - Alarm 4 Delay (ModBus Address 2213)

Alarm delay

-60:00 ÷ 60:00 mm:ss

Default: 00:00.

Negative value: Delay in exiting alarm state.

Positive value: delay on entering alarm state.

9.5 Relays Digital Outputs

P219 - Relay function 1 DO1 (ModBus Address 2219)
P221 - Relay function 2 DO2 (ModBus Address 2221)
P223 - Relay function 3 DO3 (ModBus Address 2223)
P225 - Relay function 4 DO4 (ModBus Address 2225)
P227 - Relay function 5 DO5 (ModBus Address 2227)

Various functions can be combined with the relay outputs by raising or lowering the relevant bit.

If I enable 2 functions, I get the result of the OR logic

E.g.: If I raise bit 3 (Alarm1) and bit 4 (Alarm2) on DO1, this output will be active if Alarm1 or Alarm2 is active.

Functions associated with output relay (DO):

Bit Function

- 0 Cooling Loop 1
- 1 Cooling Loop 2
- 2 Cooling Loop 3
- 3 Alarm 1
- 4 Alarm 2
- 5 Alarm 3
- 6 Alarm 4
- 7 Heater Break
- 8 RS485 Watch dog
- 9 Probe error
- 10 DI 1 state
- 11 RUN Loop 1
- 12 RUN Loop 2
- 13 RUN Loop 3
- 14 Remote 1
- 15 Remote 2

Default: 0

P220 - Alarm Contact Type DO1 (ModBus Address 2220)
P222 - Alarm Contact Type DO2 (ModBus Address 2222)
P224 - Alarm Contact Type DO3 (ModBus Address 2224)
P226 - Alarm Contact Type DO4 (ModBus Address 2226)
P228 - Alarm Contact Type DO5 (ModBus Address 2228)

Contact alarm output 5 and intervention type

- 0 n.o. (N.O.) Normally open (**Default**)
- 1 n.c. (N.C.) Normally closed

9.6 Digital Input

P233 – Digital Input 1 Function (ModBus Address 2233)

- 0 Disabled
- 1 Start / Stop (with impulse)
- 2 Run (if closed in run)
- 3 Manual alarm reset
- 4 External alarm.

The controller goes into STOP and the alarms are deactivated.

The controller does not return to START automatically: user intervention is required for this operation

P234 - Digital Input 1 Contact (ModBus Address 2234)

Defines the idle contact of digital input 1

- 0 Normally open (**Default**)
- 1 Normally closed

9.7 Soft Start

P240 - Soft-Start type Loop 1 (ModBus Address 2240)
P250 - Soft-Start type Loop 2 (ModBus Address 2250)
P260 - Soft-Start type Loop 3 (ModBus Address 2260)

Enable and select soft-start type

- | | | |
|---|--------|-----------------------------|
| 0 | Disab. | Disabled (Default) |
| 1 | Grad. | Gradient |
| 2 | Perc. | Percentage |

P241 - Soft-Start gradient Loop 1 (ModBus Address 2241)
P251 - Soft-Start gradient Loop 2 (ModBus Address 2251)
P261 - Soft-Start gradient Loop 3 (ModBus Address 2261)

Ascent/descent gradient for soft-start

0 ÷ 20000 Digit/hour (degrees.tenth/hour if temperature).

Default: 100.0

P242 - Soft-Start percentage 1 (ModBus Address 2242)
P252 - Soft-Start percentage 2 (ModBus Address 2252)
P262 - Soft-Start percentage 3 (ModBus Address 2262)

Percentage of output during soft-start function

0 ÷ 100%.

Default: 50%

P243 - Soft-Start treshold Loop 1 (ModBus Address 2243)
P253 - Soft-Start treshold Loop 2 (ModBus Address 2253)
P263 - Soft-Start treshold Loop 3 (ModBus Address 2263)

Threshold below which the percentage soft-start function is activated, when switched on

-30000 ÷ 30000 [digit] (degrees.tenth for temperature sensors)

Default: 1000

P244 - Soft-Start time Loop 1 (ModBus Address 2244)
P254 - Soft-Start time Loop 2 (ModBus Address 2254)
P264 - Soft-Start time Loop 3 (ModBus Address 2264)

Maximum soft-start duration: if the process does not reach the threshold entered in the Soft-Start Threshold (P243-P253-P263) within the set time, the controller starts adjusting to the setpoint.

00:00 Disabled
 00:01-24:00 hh:mm

Default: 00:15

9.8 Input with Current Transformer

P270 - Current Transformer function Loop 1 (ModBus Address 2270)
P280 - Current Transformer function Loop 2 (ModBus Address 2280)
P290 - Current Transformer function Loop 3 (ModBus Address 2290)

Enable CT input 1 and select mains frequency

- 0 Disabled (**Default**)
- 1 50 Hz
- 2 60 Hz

P273 - Nominal load current Loop 1 (ModBus Address 2273)
P283 - Nominal load current Loop 2 (ModBus Address 2283)
P293 - Nominal load current Loop 3 (ModBus Address 2293)

Nominal value of the connected load. Setting 0.0 disables the HB alarm

0.0 Alarm disabled. (**Default**)
 0.0-200.0 Ampere.

P274 - Heater Break sensitivity Loop 1 (ModBus Address 2274)
P284 - Heater Break sensitivity Loop 2 (ModBus Address 2284)
P294 - Heater Break sensitivity Loop 3 (ModBus Address 2294)

Percentage reduction of the measured current, below which the HB error is generated.

0-80% (**Default: 20%**)

P275 - Overcurrent Loop 1 (ModBus Address 2275)
P285 - Overcurrent Loop 2 (ModBus Address 2285)
P295 - Overcurrent Loop 3 (ModBus Address 2295)

Overcurrent alarm trip threshold for CT 1

0.0 Alarm disabled (**Default**)
 0.1-200.0 Ampere

P276 - Heater Break intervention delay Loop 1 (ModBus Address 2276)
P286 - Heater Break intervention delay Loop 2 (ModBus Address 2286)
P296 - Heater Break intervention delay Loop 3 (ModBus Address 2296)

Heater Break Alarm delay time

00:00-60:00 mm:ss
Default: 01:00

9.9 Serial RS485 Modbus RTU

P300 - Slave Address (Address ModBus 2300)

Selects the slave address for serial communication

1 ÷ 254.

Default: 247

P301 - Baud Rate (Address ModBus 2301)

Selects baud rate for serial communication

- 0 1200 bit/s
- 1 2400 bit/s
- 2 4800 bit/s
- 3 9600 bit/s
- 4 19200 bit/s (**Default**)
- 5 28800 bit/s
- 6 38400 bit/s
- 7 57600 bit/s
- 8 115200 bit/s

P302 - Serial Port Parameters (Address ModBus 2302)

Selects the format for Modbus RTU serial communication

- 0 8 bit, no parity, 1 stop bit (**Default**)
- 1 8 bit, even parity, 1 stop bit
- 2 8 bit, odd parity, 1 stop bit
- 3 8 bit, no parity, 2 stop bit
- 4 8 bit, even parity, 2 stop bit
- 5 8 bit, odd parity, 2 stop bit

P303 - Serial Delay (Address ModBus 2303)

Selects the serial delay

0 ÷ 100 ms.

Default: 5 ms.

P304 - RS485 Modbus RTU WatchDog (Address ModBus 2304)

Selects the WatchDog time. If there is no serial communication within the set time, the controller switches the output off

- 0 offline disabled (**Default**)
- 0.1-600.0 tenths of a second.

9.10 Data exchange table

List of all available addresses and supported functions

Address	Description	R/W
0	Device type	R
1	Firmware version	#### R
500	Load default values (write 9999)	R/W
1000	Value Al1	# R
1001	Value Al2	
1002	Value Al3	
1003	Real Setpoint loop 1	## con ingresso TC R
1004	Real Setpoint loop 2	
1005	Real Setpoint loop 3	
1006	Alarm status (0=absent, 1=present) Bit0 = Alarm 1 Bit1 = Alarm 2 Bit2 = Alarm 3 Bit3 = Alarm 4	R
1007	Error Flags 1 (0=absent, 1=present) Bit0 = Eeprom reading error Bit1 = Eeprom writing error Bit2 = Cold joint 1 error Bit3 = Cold joint 2 error Bit4 = Parameters out of range Bit5 = Process error Al1 (probe 1) Bit6 = Process error Al2 (probe 2) Bit7 = Process error Al3 (probe 3) Bit8 = Missing calibration error Bit9 = Generic error Bit10 = Hardware error	R
1008	Error Flags 2 (0=absent, 1=present) Bit0 = Corrupt eeprom calibration bank Bit1 = Corrupt eeprom calibration constants bank Bit2 = Corrupt setpoint bank in eeprom Bit3 = Corrupt eeprom parameter bank Bit4 = Programmable Modbus address bank, corrupt Bit5 = Data bank under password corrupt	R
1009	Dip switch status	R
1010	Digital input status (0=Open, 1=Closed) Bit0 = DI1 Bit1 = Not used	R
1011	Not used	R

Address	Description			R/W
1012	Output status (0=off, 1=on) Bit0 = Relay 1 Bit1 = Relay 2 Bit2 = Relay 3 Bit3 = Relay 4 Bit4 = Relay 5 Bit5 = SSR1 Bit6 = SSR2 Bit7 = SSR3			R
1013	LED status (0=off, 1=on) Bit0 = Relay 5 Bit1 = Relay 4 Bit2 = Relay 3 Bit3 = Relay 2 Bit4 = Relay 1 Bit5 = SSR 3 Bit6 = SSR 2 Bit7 = SSR 1 Bit8 = COM (bicolour red) Bit9 = RUN (bicolour green) Bit10 = Digital input			R
1014	Cold junction value 1 (tenths of a degree)	##		R
1015	Cold junction value 2 (tenths of a degree)	##		R
1016	Various alarms status (0=absent, 1=present) Bit0 = Alarm 1 Bit1 = Alarm 2 Bit2 = Alarm 3 Bit3 = Alarm 4 Bit4 = Low current H.B.A. 1 Bit5 = Low current H.B.A. 2 Bit6 = Low current H.B.A. 3 Bit7 = Short circuit H.B.A. 1 Bit8 = Short circuit H.B.A. 2 Bit9 = Short circuit H.B.A. 3 Bit10 = Process AI1 error (probe 1) Bit11 = Process AI2 error (probe 2) Bit12 = Process AI3 error (probe 3) Bit13 = Digital input status Bit14 = Off-Line status			R
1017	RS 485 WatchDog 0 = OK 1 = In Error			R
1050	Instantaneous current value CT1	##	CT1	R
1051	Average current value CT1	##		R
1052	Current value ON CT1	##		R
1053	Current value OFF CT1	##		R
1054	Instantaneous current value CT2	##	CT2	R
1055	Average current value CT2	##		R
1056	Current value ON CT2	##		R
1057	Current value OFF CT2	##		R

Address	Description			R/W
1058	Instantaneous current value CT3	##	CT3	R
1059	Average current value CT3	##		R
1060	Current value ON CT3	##		R
1061	Current value OFF CT3	##		R
1062	HB status: Low current (0 = absent; 1 = present) Bit0 = CT 1 Bit1 = CT 2 Bit2 = CT 3			R
1063	HB status: Short circuit (0 = absent; 1 = present) Bit0 = CT 1 Bit1 = CT 2 Bit2 = CT 3			R
1064	HB status: Overcurrent (0 = absent; 1 = present) Bit0 = CT 1 Bit1 = CT 2 Bit2 = CT 3			R
1100	Configuration Password			R/W
1200	Setpoint 1		##	R/W
1201	Setpoint 2		##	R/W
1202	Setpoint 3		##	R/W
1203	Alarm 1 setpoint If "ALM1 Function" = "Asymmetric Band": Upper alarm 1 setpoint	##	AL1	R/W
1204	If "ALM1 Function" = "Asymmetric Band" Lower alarm 1 setpoint	##		R/W
1205	Alarm 2 setpoint If "ALM2 Function" = "Asymmetric Band" Upper alarm 2 setpoint	##	AL2	R/W
1206	If "ALM2 Function" = "Asymmetric Band" Lower alarm 2 setpoint	##		R/W
1207	Alarm 3 setpoint If "ALM3 Function" = "Asymmetric Band" Upper alarm 3 setpoint	##	AL3	R/W
1208	If "ALM3 Function" = "Asymmetric Band" Lower alarm 3 setpoint	##		R/W
1209	Alarm 4 setpoint If "ALM4 Function" = "Asymmetric Band" Upper alarm 4 setpoint	##	AL4	R/W
1210	If "ALM4 Function" = "Asymmetric Band" Lower alarm 4 setpoint	##		R/W
1211	Start / Stop regulation Loop 1 0 = Loop 1 in STOP 1 = Loop 1 in START			R/W

Address	Description			R/W
1212	Start / Stop regulation Loop 2 0 = Loop 2 in STOP 1 = Loop 2 in START			R/W
1213	Start / Stop regulation Loop 3 0 = Loop 3 in STOP 1 = Loop 3 in START			R/W
1214	Start / Stop regulation Loop 1-2-3 Bit0 = Loop 1 Bit1 = Loop 2 Bit2 = Loop 3			R/W
1215	Auto/manual selection regulation Loop 1-2-3 Bit0 = Loop 1 Bit1 = Loop 2 Bit2 = Loop 3			R/W
1216	Tune management regulation Loop 1 With Pre Tune Reading 0 = not in function 1 = in function Writing 0 = steady 1 = active			RW
	----- With Self Tune Writing 0 = not in function 1 = in function			RO
1217	Tune management regulation Loop 2 (See word 1216)			R/W
1218	Tune management regulation Loop 3 (See word 1216)			R/W
1219	Auto/manual selection regulation Loop 1 0 = auto 1 = manual			R/W
1220	Auto/manual selection regulation Loop 2 0 = auto 1 = manual			R/W
1221	Auto/manual selection regulation Loop 3 0 = auto 1 = manual			R/W
1222	Command output percentage for regulation Loop 1 (0 ÷ 10000)	####	Loop 1 Heat	R
1223	Command output percentage for regulation Loop 1 (0 ÷ 1000)	####		R
1224	Command output percentage for regulation Loop 1 (0 ÷ 100)	###		R

Address	Description			R/W
1225	Cold output percentage with Loop 1 regulation (0 ÷ 10000)	####.	Loop 1 Cool	R
1226	Cold output percentage with Loop 1 regulation (0 ÷ 1000)	####.		R
1227	Cold output percentage with Loop 1 regulation (0 ÷ 100)	###		R
1228	Hot only, Manual control output percentage for Loop 1 (0÷10000) Hot/Cold, Manual control output percentage for Loop 1 (-10000 ÷ 10000)	####.	Loop 1 Manual	R/W
1229	Hot only, Manual control output percentage for Loop 1 (0÷1000) Hot/Cold, Manual control output percentage for Loop 1 (-1000 ÷ 1000)	####.		R/W
1230	Hot only, Manual control output percentage for Loop 1 (0 ÷ 100) Hot/Cold, Manual control output percentage for Loop 1 (-100 ÷ 100)	###		R/W
1231	Command output percentage for regulation Loop 2 (0 ÷ 10000)	####.	Loop 2 Heat	RO
1232	Command output percentage for regulation Loop 2 (0 ÷ 1000)	####.		RO
1233	Command output percentage for regulation Loop 2 (0 ÷ 100)	###		RO
1234	Cold output percentage with Loop 2 regulation (0 ÷ 10000)	####.	Loop 2 Cool	RO
1235	Cold output percentage with Loop 2 regulation (0 ÷ 1000)	####.		RO
1236	Cold output percentage with Loop 2 regulation (0 ÷ 100)	###		RO
1237	Hot only, Manual control output percentage for Loop 2 (0÷10000) Hot/Cold, Manual control output percentage for Loop 2 (-10000 ÷ 10000)	####.	Loop 2 Manual	R/W
1238	Hot only, Manual control output percentage for Loop 2 (0÷1000) Hot/Cold, Manual control output percentage for Loop 2 (-1000 ÷ 1000)	####.		R/W
1239	Hot only, Manual control output percentage for Loop 2 (0 ÷ 100) Hot/Cold, Manual control output percentage for Loop 2 (-100 ÷ 100)	###		R/W

Address	Description			R/W
1240	Perc. uscita freddo con regolazione Loop 3 (0 ÷ 10000)	####		RO
1241	Perc. uscita freddo con regolazione Loop 3 (0 ÷ 1000)	####	Loop 3 Heat	RO
1242	Perc. uscita freddo con regolazione Loop 3 (0 ÷ 100)	###		RO
1243	Cold output percentage with Loop 3 regulation (0 ÷ 10000)	####		RO
1244	Cold output percentage with Loop 3 regulation (0 ÷ 1000)	####	Loop 3 Cool	RO
1245	Cold output percentage with Loop 3 regulation (0 ÷ 100)	###		RO
1246	Hot only, Manual control output percentage for Loop 3 (0 ÷ 10000) Hot/Cold, Manual control output percentage for Loop 3 (-10000 ÷ 10000)	####		R/W
1247	Hot only, Manual control output percentage for Loop 3 (0 ÷ 1000) Hot/Cold, Manual control output percentage for Loop 3 (-1000 ÷ 1000)	####	Loop 3 Manual	R/W
1248	Hot only, Manual control output percentage for Loop 3 (0÷100) Hot/Cold, Manual control output percentage for Loop 3 (-100 ÷ 100)	###		R/W
1249	Manual Alarm 1 reset: Writing: 0 = to reset Reading: 0 = non-resettable 1 = resettable			R/W
1250	Manual Alarm 2 reset: Writing: 0 = to reset In lettura: 0 = non-resettable 1 = resettable			R/W
1251	Manual Alarm 3 reset: Writing: 0 = to reset Reading: 0 = non-resettable 1 = resettable			R/W
1252	Manual Alarm 4 reset: Writing: 0 = to reset Reading: 0 = non-resettable 1 = resettable			R/W
1253	Not used			R/W

Address	Description	R/W	
1254	Manual alarms reset: write "0" to reset all alarms Reading: 0 = non-resettable 1 = resettable Bit0 = Alarm 1 Bit1 = Alarm 2 Bit2 = Alarm 3 Bit3 = Alarm 4 Bit4 = Alarm 5	R/W	
1301	Alarm 1 status remote 0 = absent 1 = present	R/W	
1302	Alarm 2 status remote 0 = absent 1 = present	R/W	
1401	Word assigned to the address 2501	R	
...	Word assigned to the address 25xx	R	
1430	Word assigned to the address 2530	R	
1431	Word assigned to the address 2531	R	
2001	Parameter 1	see product manual	R/W
...	Parameter ...		R/W
2303	Parameter 303		R/W
2304	Parameter 304		R/W
2501	Word reading address assignment 1401	R/W	
...	Word reading address assignment 14xx	R/W	
2530	Word reading address assignment 1430	R/W	
2531	Word reading address assignment 1431	R/W	
3001	Instrument Info	R/W	
...	...	R/W	
3022	Instrument Info	R/W	
3023	Instrument Info	R/W	

10 Inputs and outputs

Inputs and outputs can also be used as simple inputs and outputs read from the serial without any function connected.

To enable them, simply configure the parameters correctly.

10.1 Analog inputs

Set input type and scale in the 'input' section of loop1, loop2 and loop3

Name: DefaultRecipe

- Loop1**
 - Input
 - 2001 2001 Input 1 **4..20mA**
 - 2002 2002 Low limit **0**
 - 2003 2003 Upper Limit **1000**
 - 2004 2004 Over Limits **Disabled**
 - 2005 2005 Offset **0**
 - 2006 2006 Gain **0.0**
 - 2007 2007 Filter **0**
 - 2008 2008 Degree **°C**
 - 2009 2009 Conversion Frequency **4.17Hz**
 - Heat Output
 - PID
 - Soft start
 - CT
 - Monitor
- Loop2**
 - Input
 - 2015 2015 Input 2 **Disabled**
 - 2016 2016 Low limit **0**
 - 2017 2017 Upper Limit **1000**
 - 2018 2018 Over Limits **Disabled**
 - 2019 2019 Offset **0**
 - 2020 2020 Gain **0.0**
 - 2021 2021 Filter **0**
 - Heat Output
 - PID
 - Soft start
 - CT
 - Monitor
- Loop3**
 - Input
 - 2029 2029 Input 3 **Disabled**
 - 2030 2030 Low limit **0**
 - 2031 2031 Upper Limit **1000**
 - 2032 2032 Over Limits **Disabled**
 - 2033 2033 Offset **0**
 - 2034 2034 Gain **0.0**
 - 2035 2035 Filter **0**
 - Heat Output
 - PID
 - Soft start

Their value will be available at the following address:

- Input1 1000
- Input2 1001
- Input3 1002

10.2 Digital input

Set the function of the digital input in "No function"

Name: DefaultRecipe
 Loop1
 Loop2
 Loop3
 Alarms / Cooling / Staus
 Relè Output
 Ingressi digitali
 DI1
 2233 2233 DI1 Function
 2234 2234 Input Contact type
 Porta seriale

No Function
Normaly Open

The status of the digital input is available in parameter 1010 on bit 0

Input status	Normally Open	Normally Closed
Open	0	1
Closed	1	0

10.3 Current transformer input CT

Allows current values to be read via a current transformer (see section 9.8).
Set 'CT Funcion' and 'Size' for each channel

Name: DefaultRecipe				
Loop1				
Input				
Heat Output				
PID				
Soft start				
CT				
2270	2270	CT1 Function		50 Hz
2271	2271	Size	A	50
2272	2272	Adjust	-	0.00
2273	2273	Load Nom. Curr.	A	0.0
2274	2274	HB Sens	%	0
2275	2275	Overcurrent Alarm Threshold	A	0.0
2276	2276	Delay	mm:ss	0.00
Monitor				
Loop2				
Input				
Heat Output				
PID				
Soft start				
CT				
2280	2280	CT2 Function		50 Hz
2281	2281	Size	A	50
2282	2282	Adjust	-	0.00
2283	2283	Load Nom. Curr.	A	0.0
2284	2284	HB Sens	%	0
2285	2285	Overcurrent Alarm Threshold	A	0.0
2286	2286	Delay	mm:ss	0.00
Monitor				
Loop3				
Input				
Heat Output				
PID				
Soft start				
CT				
2290	P290	CT3 Function		50 Hz
2291	P291	Size	A	50
2292	P292	Adjust	-	0.00
2293	P293	Load Nom. Curr.	A	0.0
2294	P294	HB Sens	%	0
2295	P295	Overcurrent Alarm Threshold	A	0.0
2296	P296	Delay	mm:ss	0.00
Monitor				

Their value will be available at the following address:

- Current value CT1 1050
- Current value CT2 1054
- Current value CT3 1058

10.4 Relay output

The 5 relay outputs can be controlled by serial communication, only with 2 signals but freely combinable with each other.

For example, to control DO1 and DO3 with one signal and DO2 and DO4 with another signal, you would have to configure:

- "Remote 1" on "Relay 1 Function" and "Relay 3 Function",
- "Remote 2" on "Relay 2 Function" and "Relay 4 Function".

The screenshot shows a configuration tree for relay outputs. The left pane shows a hierarchy: Loop1, Loop2, Loop3, Alarms / Cooling / Staus, Relè Output, DO1, DO2, DO3, DO4. The right pane shows the configuration for each output. For example, DO1 (2219 P219) is configured with 'Relè 1 Function' and 'Relè 1 type'. The status for most functions is '- Disabled -', while 'Remote 1' and 'Remote 2' are 'Enabled'. The output type is 'N.O.'. Similar configurations are shown for DO2, DO3, and DO4.

To control the 2 signals:

- Remote 1 --> Parameter 1301 Bit 0
- Remote 2 --> Parameter 1302 Bit 0

Remote signal	Output Type Relè N.O.	Output Type Relè N.C.
0	Open	Close
1	Close	Open

10.5 SSR outputs

The 3 SSR outputs can be controlled by serial communication individually. For each output to be controlled, set the 'Auto/Manul' parameter to Manual.

<ul style="list-style-type: none"> Loop1 <ul style="list-style-type: none"> Input <ul style="list-style-type: none"> Heat Output <ul style="list-style-type: none"> 1219 1219 2043 2043 2044 2044 2045 2045 2046 2046 2047 2047 2048 2048 2049 2049 2050 2050 2051 2051 2052 2052 2053 2053 PID Soft start CT Monitor 	<ul style="list-style-type: none"> Auto/Manuale L1 Command Out 1 L1 Initial state Command Process Command Origin SP Action Type Hysteresis Out with Input error error control Type Out % when in Stop Manual status Stored ECO Mode 	<ul style="list-style-type: none"> Manual Enabled Start PV1 SP1 Heat 2 0 0 Input 1 Only 0 Disabled Disabled
---	---	--

To control the outputs use:

- Out1 --> Parameter 1230
- Out2 --> Parameter 1239
- Out3 --> Parameter 1248

Value	Output
0	ON 12Vdc
100	OFF 0Vdc
1 – 99	Modulating output



CD Automation S.r.l.

Via Picasso, 34/36 - 20025 Legnano (MI)- Italy

Tel. +39 0331 577479 - Fax +39 0331 579479

E-mail: info@cdautomation.com - Web: www.cdautomation.com