

# CD1800 DIGITAL INDICATOR



**CD1800** Digital Indicator is a panel mounting instrument designed to have a digital indication of low and high DC voltage inputs.

3½ Digit display (1999) with automatic sign indication.

Precision is 0.1% ± 1Digit.

## APPLICATION

The most common application are:

- RPM indication from tacho signal
- Current indication with signal from DC-Drive/Inverter
- Speed indication from tacho signal or from DC-Drive/Inverter
- Pull indication from a load cell
- Position indication from linear transducer
- Digital voltmeter

## MAIN FEATURES

- Very competitive price
- High efficiency 3½ digit Display.
- Stick on labels for Engineering units
- Internal power supply for linear transducer +5 -5V
- Three wires potentiometer input with zero position tuning capability
- Inputs and decimal points adjustable via jumpers

## DIMENSION

Frontal dimension: 48x96mm

Depth: 83mm

Panel cutout: 45x92mm

Cas material: Noryl UL 94 V-O auto extinguishing

Weight: 300grams.

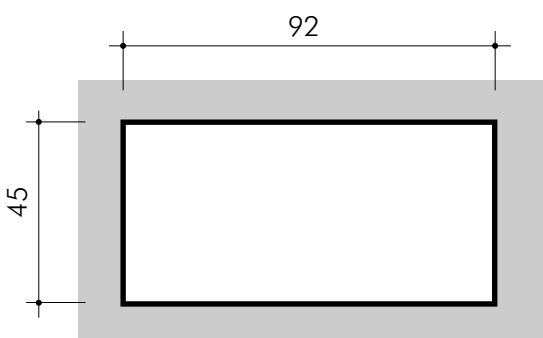
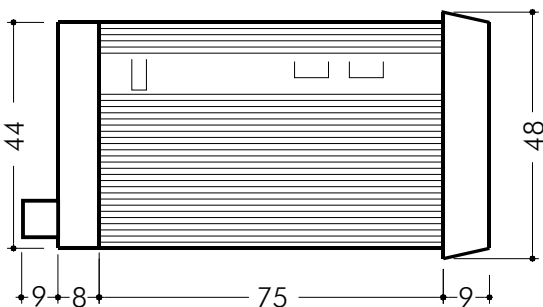
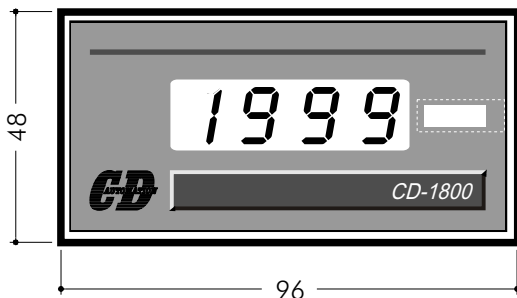

## TECHNICAL DATA

Input type	0-5 Vdc Impedance >100 Kohm
	0-10 Vdc Impedance >100 Kohm
	0-100 Vdc Impedance >100 Kohm
	0-200 Vdc Impedance >100 Kohm
	4-20 mA Impedance =250 Ohm
Precision	± 0,1% f.s. ±1 digit
Repeatability	± 0,1% f.s.
Scale range	± 1999 3½ digit
Voltage supply	115-230 Vac ±10%
Consumption	3 VA
Thermal drift	± 200 ppm/°C
Display	LED 7 segments 13 mm
Decimal point position	Dip switch selectable
Zero adjust	± 150 digit
Span adjust	50%÷150% span
Linear transducer voltage supply	± 5 V - 5 V 10mA max
Working temperature	0÷ +45 °C (U.R.<90%)
Stocking temperature	0÷ +60 °C (U.R.<90%)
Wiring connection	Screw terminals
Protection	IP 30
Case material	Auto extinguishing Noryl UL 94 V-O
Weight	300 grams

## INPUT SELECTION VIA BANK SWITCH BS1

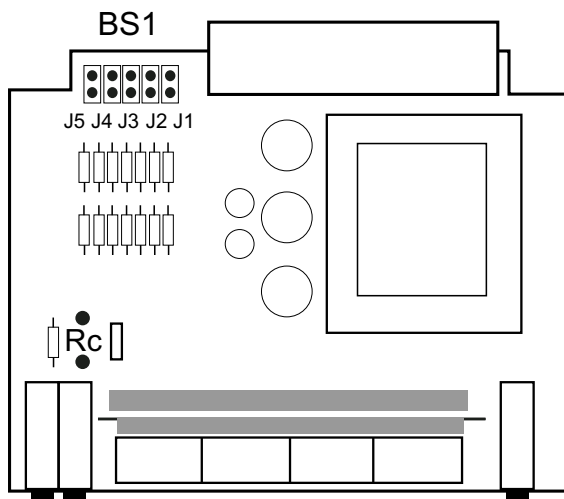

The indicator is supplied pre-configured to the order code.

Re-configuration of inputs is easy archived by the user following the below instructions.

- J5 closed 0÷ 5Vdc
- J4 closed 0÷ 10Vdc
- J3 closed 0÷100Vdc
- J2 closed 0÷200Vdc
- J1 closed 4÷ 20mA

When input 4÷20mA has been chosed mount RC=100Kohm

## ZERO SPAN TUNING

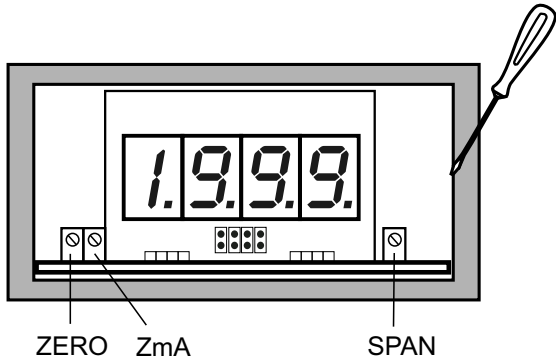

Remove the frontal flat display filter with a small screwdriver and you will gain access to tuning potentiometers for Zero and Span scale.

Tune the span pot until to have the desired full scale indication. After which tune zero pot up to have Zero read out on display. After which control again the span indication.

When 4÷20mA has been used with 4mA input adjust ZmA potentiometer to have Zero read out.

## DECIMAL POINT SELECTION VIA BANK SWITCH BS2

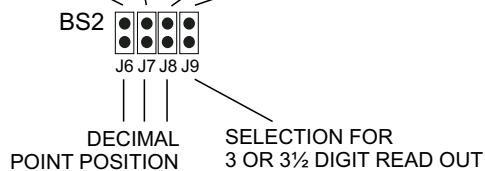
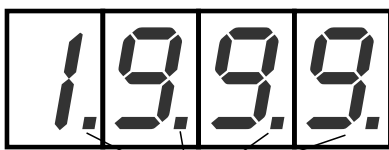

J6 closed 1.999 read out  
 J7 closed 19.99 read out  
 J8 closed 199.9 read out

J9 closed 1999 3 1/2 digit read out  
 J9 open 199 3 digit read out

## WIRING CONNECTIONS

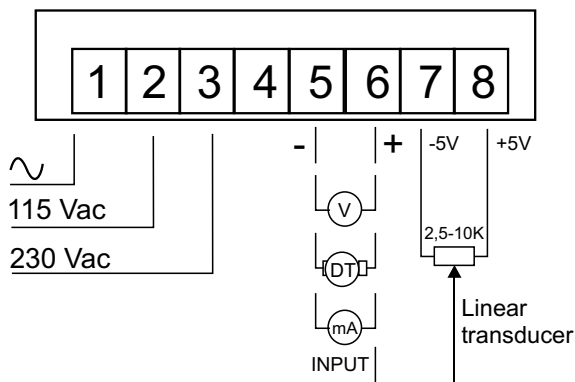

## INDICATOR CODE

**Code**                      **CD1800 / - - - - / - / M -**

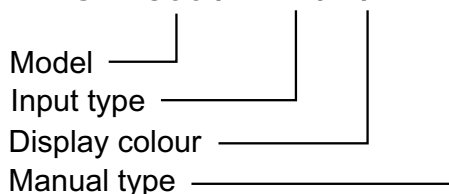

### MODEL

Digital indicator CD1800

### INPUT TYPE

Code	Description
0005	0-5 Vdc
0010	0-10 Vdc
0100	0-100 Vdc
0200	0-200 Vdc
0420	4-20 mA

### OPTION

Code	Description
R	Red LED display
V	Green LED display

### TYPE MANUAL

Code	Description
1	Italian manual
2	English manual

In normal operation, the operator must not remove the indicator from its housing or have unrestricted access to the rear terminals, as this would provide potential contact with hazardous live parts.

Installation and configuration must be undertaken by technically competent servicing personnel.

Comply with EMC specification,  mark.



Controllers, Drives & Automation  
CD Automation s.r.l.  
via Picasso, 34/36  
20025 Legnano (MI) - ITALIA  
Tel. 0039-331-577479 Fax 0039-331-579479  
E-MAIL: [info@cdautomation.com](mailto:info@cdautomation.com)  
WEB: [www.cdautomation.com](http://www.cdautomation.com)

## ENGINEERING UNITS

%	%	%	%	%	%
bar	bar	bar	bar	bar	bar
mbar	mbar	mbar	mbar	mbar	mbar
m <sup>3</sup> /h r	m <sup>3</sup> /h r	m <sup>3</sup> /h r	m <sup>3</sup> /h r	m <sup>3</sup> /h r	m <sup>3</sup> /h r
rpm	rpm	rpm	rpm	rpm	rpm
ppm	ppm	ppm	ppm	ppm	ppm
%RH	%RH	%RH	%RH	%RH	%RH
psi	psi	psi	psi	psi	psi
mV	mV	mV	mV	mV	mV
V	V	V	V	V	V
mA	mA	mA	mA	mA	mA
A	A	A	A	A	A
kW	kW	kW	kW	kW	kW
W	W	W	W	W	W
Kg	Kg	Kg	Kg/s	Kg/s	Kg/s
Kg/h	Kg/h	Kg/h	litres	litres	litres
l/s	l/s	l/s	l/h	l/h	l/h
°F	°F	°F	°F	°F	°F
°C	°C	°C	°C	°C	°C
mt/s	mt/s	mt/s	mt/min	mt/min	μ
Hz	Hz	Hz	Hz	Hz	μ

Cut the engineering unity desired and insert it in the window on the front of the CD1800

## ENGINEERING UNITS

%	%	%	%	%	%
bar	bar	bar	bar	bar	bar
mbar	mbar	mbar	mbar	mbar	mbar
m <sup>3</sup> /h r	m <sup>3</sup> /h r	m <sup>3</sup> /h r	m <sup>3</sup> /h r	m <sup>3</sup> /h r	m <sup>3</sup> /h r
rpm	rpm	rpm	rpm	rpm	rpm
ppm	ppm	ppm	ppm	ppm	ppm
%RH	%RH	%RH	%RH	%RH	%RH
psi	psi	psi	psi	psi	psi
mV	mV	mV	mV	mV	mV
V	V	V	V	V	V
mA	mA	mA	mA	mA	mA
A	A	A	A	A	A
kW	kW	kW	kW	kW	kW
W	W	W	W	W	W
Kg	Kg	Kg	Kg/s	Kg/s	Kg/s
Kg/h	Kg/h	Kg/h	litres	litres	litres
l/s	l/s	l/s	l/h	l/h	l/h
°F	°F	°F	°F	°F	°F
°C	°C	°C	°C	°C	°C
mt/s	mt/s	mt/s	mt/min	mt/min	μ
Hz	Hz	Hz	Hz	Hz	μ

Cut the engineering unity desired and insert it in the window on the front of the CD1800